

---

## TOA MICROPHONE

---

# DYNAMIC MICROPHONES

---

**DM-1100 Lecture, Speech use / DM-1200 Speech use**  
**DM-1300 Speech, Vocal use / DM-1500 Vocal use**

---



### DESCRIPTION

**DM-1100** Designed for both hand-held and stand mounting uses, the TOA DM-1100 is a unidirectional dynamic microphone suited for general sound applications. The microphone has a short-off type slide on/off switch to minimize switching noise and is fitted with a 7.5 m single-core shielded cable with an unbalanced 1/4" phone plug. The microphone body is rigidly constructed of diecast aluminum, and designed to reduce handling noise. The microphone is supplied with a microphone holder that is adaptable to both W5/16" and W5/8" threads.

**DM-1200** Designed for both hand-held and stand mounting uses, the TOA DM-1200 is a unidirectional dynamic microphone suited for speech applications. The microphone has a short-off type slide on/off switch to reduce switching noise and has an XLR type 3-pin male connector as well. The microphone body is rigidly constructed of diecast zinc, and is designed to reduce handling noise. The microphone comes with a microphone holder that is adaptable to W5/16", W3/8" and W5/8" threads, and with a 10m single-core shielded cable with an unbalanced 1/4" phone plug.

**DM-1300** Designed for both hand-held and stand mounting uses, the TOA DM-1300 is a unidirectional dynamic microphone suited for speech and vocal applications. The microphone has a short-off type slide on/off switch to reduce switching noise and has an XLR type 3-pin male connector as well. The microphone body is rigidly constructed of diecast zinc, and is designed to reduce handling noise. The microphone comes with a microphone holder that is adaptable to W5/16" threads, and with a 10m single-core shielded cable with an unbalanced 1/4" phone plug.

**DM-1500** Designed for both hand-held and stand mounting uses, the TOA DM-1500 is a unidirectional dynamic microphone suited for vocal applications. The microphone has a short-off type slide on/off switch to reduce switching noise and has an XLR type 3-pin male connector as well. The microphone body is rigidly constructed of diecast zinc, and is designed to reduce handling noise. The microphone comes with a microphone holder that is adaptable to W5/16" threads, and with a 10m 2-core shielded cable with unbalanced 1/4" phone plug.

### FEATURES

Unidirectional microphone reduces acoustic feedback.

Short-off type slide on/off switch minimizes switching noise.

Robust diecast zinc ( DM-1100: diecast aluminium ) microphone body reduces handling noise.

Microphone holder and 10 m shielded cable ( DM-1100: 7.5 meters ) provided as standard accessory.



TOA Corporation  
[www.amthanhtoa.vn](http://www.amthanhtoa.vn)

# SPECIFICATION

	DM-1100	DM-1200	DM-1300	DM-1500
Type	Moving coil microphone (Dynamic microphone)			
Directivity	Unidirectional			
Rated impedance	600 Ω, unbalanced	600 Ω, balanced		
Rated sensitivity (1 kHz 0 dB = 1 V/Pa)	-55 dB		-54 dB	-56 dB
Frequency response	100 Hz – 12,000 Hz	50 Hz – 12 kHz	70 Hz – 15 kHz	70 Hz – 15 kHz
Connection cable	1-core shielded cable	1-core shielded cable, unbalanced		2-core shielded cable, unbalanced
Cable length	7.5 m	10 m		
Terminal of cable	1/4" unbalanced phone plug			
Weight	155 g (without connection cable)	265 g (without connection cable)	245 g (without connection cable)	280 g (without connection cable)
Dimensions (W x H x D)	ø 55 x 178 mm	ø 39.5 x 163 mm	ø 51 x 170 mm	ø 40.5 x 173 mm
Talk switch	Short-off type, slide on/off switch			
Finish	Body: Die cast aluminum, painted black Head: ABS resin, black/ zinc plated steel wire, painted black	Body: Die cast zinc, painted metallic gray Head: Die cast aluminum, zinc plated steel wire, painted metallic gray	Body: Die cast zinc, painted metallic gray Head: Aluminum, zinc plated steel wire, painted metallic gray	Body: Die cast zinc, painted metallic gold Head: Brass and zinc plated steel wire, painted metallic gold
Standard accessory	Microphone holder (W 5/16", W 5/8")	Microphone holder (W 5/16", W 5/8", W 3/8")	Microphone holder (W 5/16")	Microphone holder (W 5/16")

## APPEARANCE AND DIMENSIONAL DIAGRAM

**DM-1100**

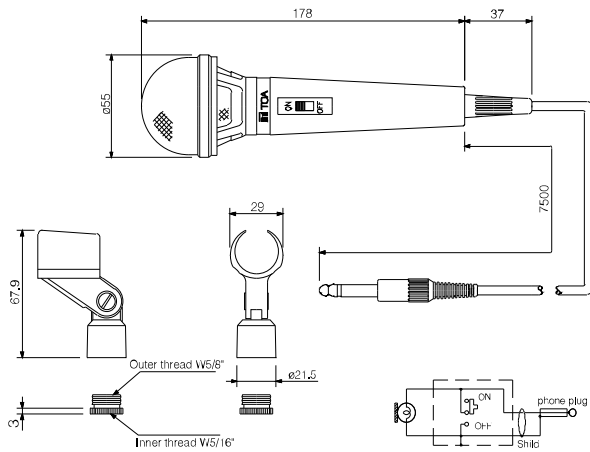

**DM-1200**

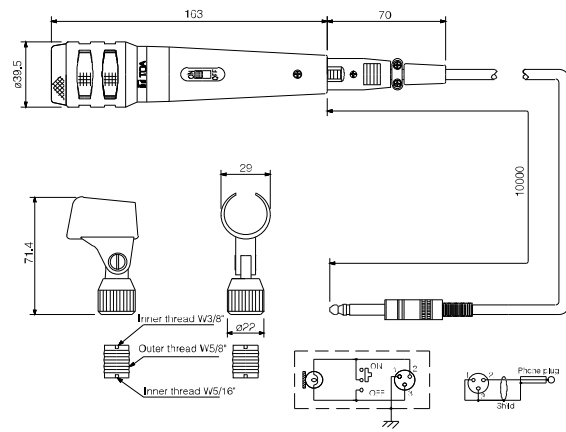

**DM-1300**

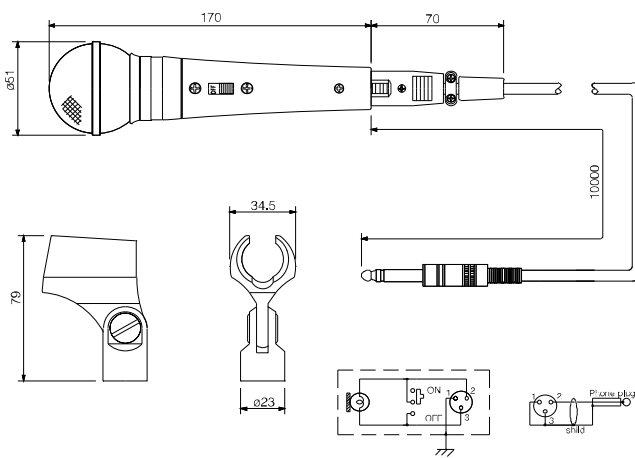

**DM-1500**

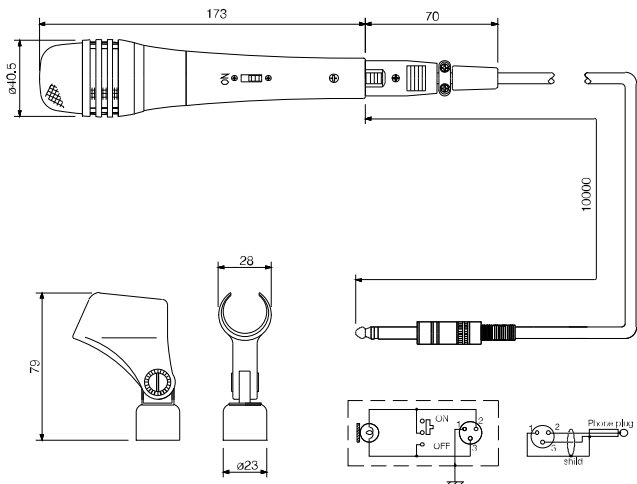

Unit: mm



TOA

www.amthanhtoavietnam.vn