

DESCRIPTION

The FB-08BT is an indoor subwoofer system featuring a high-performance 20 cm (8") driver. An integrated crossover network simplifies system configuration, allowing seamless integration with F-03/05 series speakers without the need for additional processors. This delivers powerful bass reproduction for a wide range of applications. The FB-08BT offers flexible installation options, supporting both low and high impedance connections. Optional mounting brackets are available for secure wall or ceiling mounting.

SPECIFICATIONS

Enclosure	Bass-reflex type
Power Handling Capacity (*1)	Rated noise power: 120 W (8 Ω) Continuous program: 240 W (8 Ω)
Rated Input	120 W (100 V line, 70 V line)
Rated Impedance	8 Ω 100 V line: 83 Ω (120 W), 167 Ω (60 W) 70 V line: 50 Ω (100 W), 83 Ω (60 W), 167 Ω (30 W)
Sensitivity	84 dB (1 W, 1 m) at installation in free sound field 90 dB (1 W, 1 m) at installation in 1/2 free sound field
Frequency Response	45 - 300 Hz, -10 dB at installation in 1/2 free sound field
Speaker Component	20 cm (8") cone-type
Input Terminal	M4 screw terminal, distance between barriers: 9 mm (0.35")
Operating Temperature	-10 °C to +50 °C (14 °F to 122 °F)
Installation Environment	Indoor installation
Recommended Amplifiers (*2)	DA-250DH, DA-250FH, DA-500FH, A-5012
Finish	Enclosure: MDF, black (RAL 9011 equivalent), paint Grille: Surface treated steel plate, black (RAL 9011 equivalent), paint
Dimensions	200 (W) × 350 (H) × 400 (D) mm (7.87" × 13.78" × 15.75")
Weight	16 kg (3.53 lb)
Option	Subwoofer wall mounting bracket: HY-WM-FB08B Subwoofer ceiling mounting bracket: HY-CM-FB08B

(*1) Rated noise power is defined by IEC60268-5. Continuous program is 3 dB above Rated noise power.

(*2) If you do not use the recommended amplifier, the speaker's performance may suffer, and the amplifier's protection function may cause sound interruptions. We strongly recommend using the suggested amplifier.

Note: Bolts and nuts for mounting the bracket to the wall or ceiling are not included. Prepare them separately.

APPEARANCE

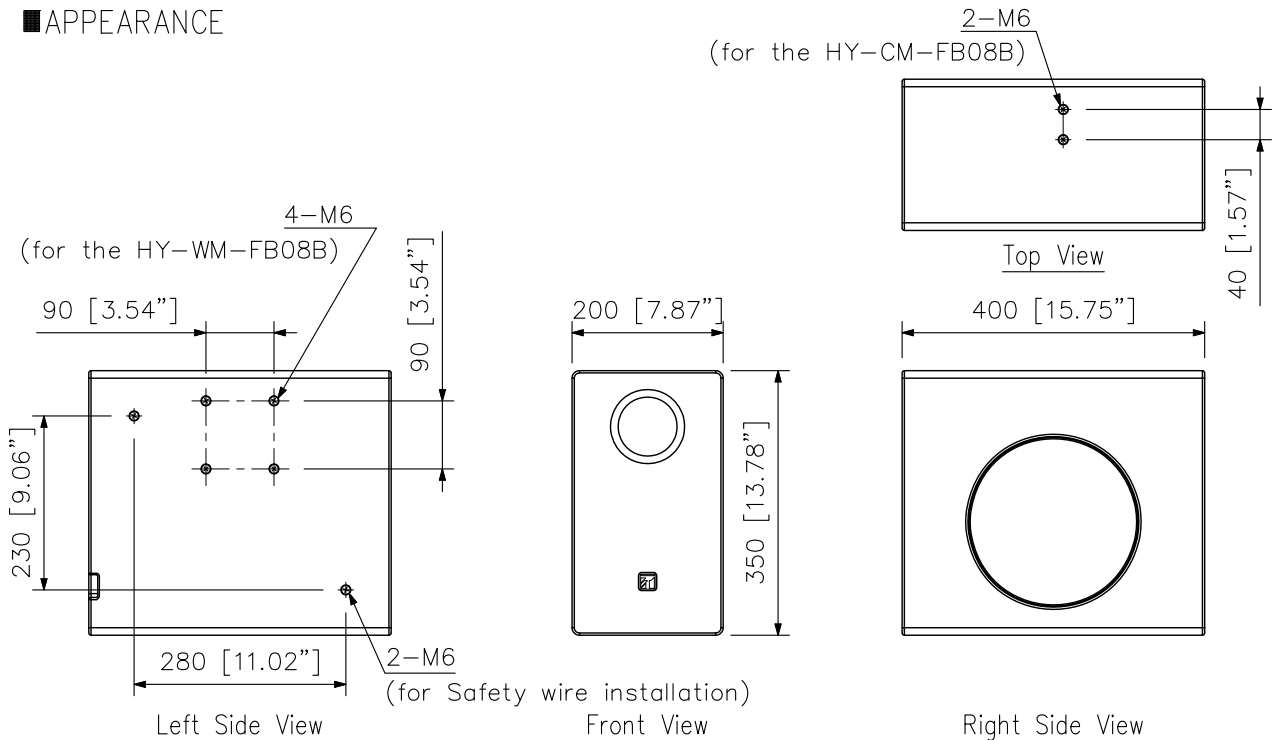

UNIT:mm SCALE:1/10

■ APPEARANCE

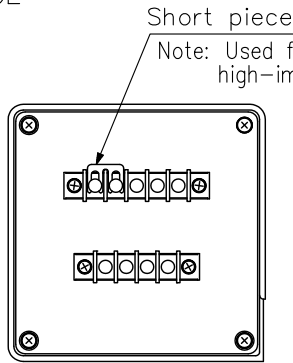

Enlarged view of Input terminal

Rear View

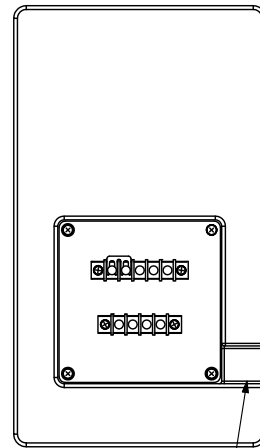

Notch

Note: The cables can be pulled out from the notch.

Circuit diagram

When using high impedance connection

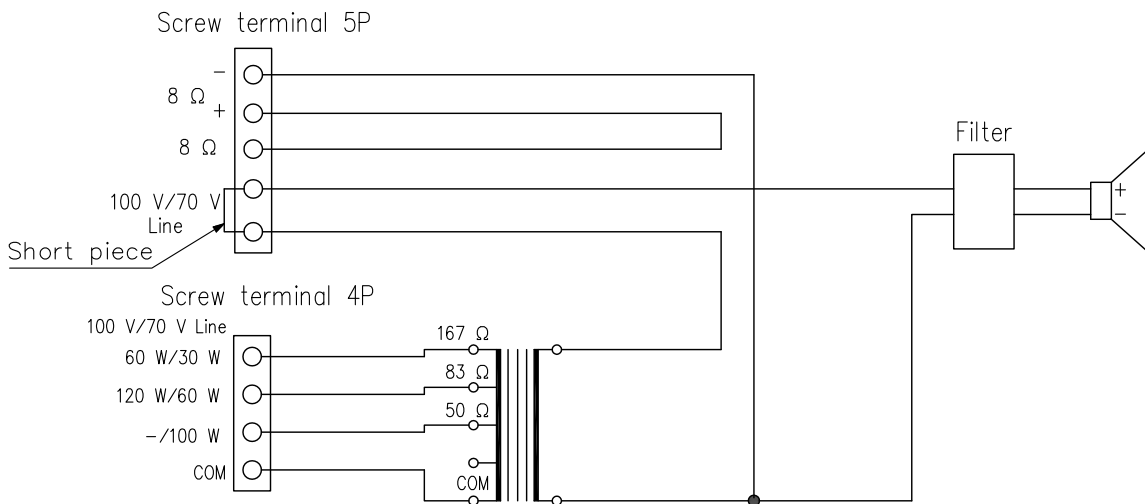

When using low impedance connection

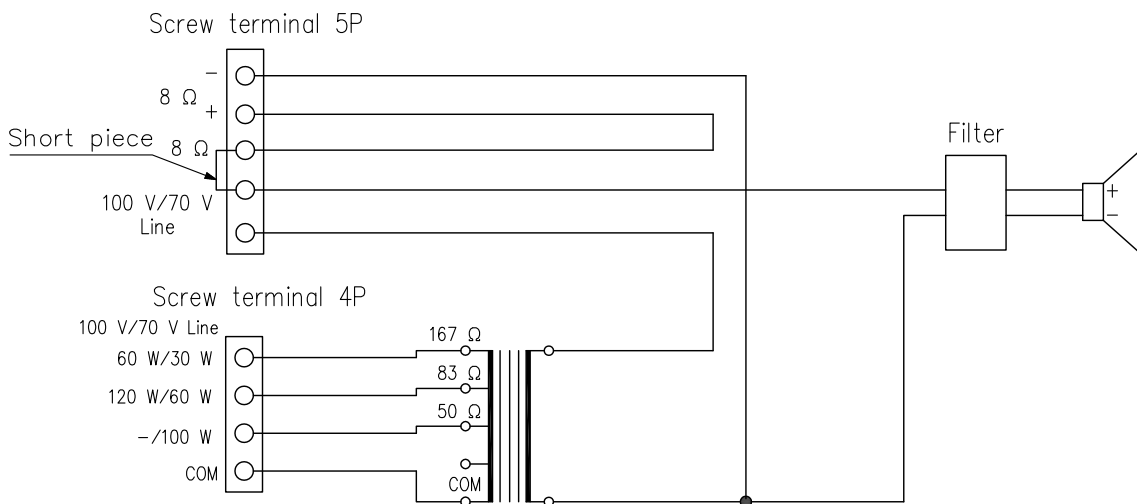

UNIT: mm SCALE: 1/6

DESCRIPTION

The FB-08WT is an indoor subwoofer system featuring a high-performance 20 cm (8") driver. An integrated crossover network simplifies system configuration, allowing seamless integration with F-03/05 series speakers without the need for additional processors. This delivers powerful bass reproduction for a wide range of applications. The FB-08WT offers flexible installation options, supporting both low and high impedance connections. Optional mounting brackets are available for secure wall or ceiling mounting.

SPECIFICATIONS

Enclosure	Bass-reflex type
Power Handling Capacity (*1)	Rated noise power: 120 W (8 Ω) Continuous program: 240 W (8 Ω)
Rated Input	120 W (100 V line, 70 V line)
Rated Impedance	8 Ω 100 V line: 83 Ω (120 W), 167 Ω (60 W) 70 V line: 50 Ω (100 W), 83 Ω (60 W), 167 Ω (30 W)
Sensitivity	84 dB (1 W, 1 m) at installation in free sound field 90 dB (1 W, 1 m) at installation in 1/2 free sound field
Frequency Response	45 - 300 Hz, -10 dB at installation in 1/2 free sound field
Speaker Component	20 cm (8") cone-type
Input Terminal	M4 screw terminal, distance between barriers: 9 mm (0.35")
Operating Temperature	-10 °C to +50 °C (14 °F to 122 °F)
Installation Environment	Indoor installation
Recommended Amplifiers (*2)	DA-250DH, DA-250FH, DA-500FH, A-5012
Finish	Enclosure: MDF, white (RAL 9016 equivalent), paint Grille: Surface treated steel plate, white (RAL 9016 equivalent), paint
Dimensions	200 (W) x 350 (H) x 400 (D) mm (7.87" x 13.78" x 15.75")
Weight	16 kg (3.53 lb)
Option	Subwoofer wall mounting bracket: HY-WM-FB08W Subwoofer ceiling mounting bracket: HY-CM-FB08W

(*1) Rated noise power is defined by IEC60268-5. Continuous program is 3 dB above Rated noise power.

(*2) If you do not use the recommended amplifier, the speaker's performance may suffer, and the amplifier's protection function may cause sound interruptions. We strongly recommend using the suggested amplifier.

Note: Bolts and nuts for mounting the bracket to the wall or ceiling are not included. Prepare them separately.

APPEARANCE

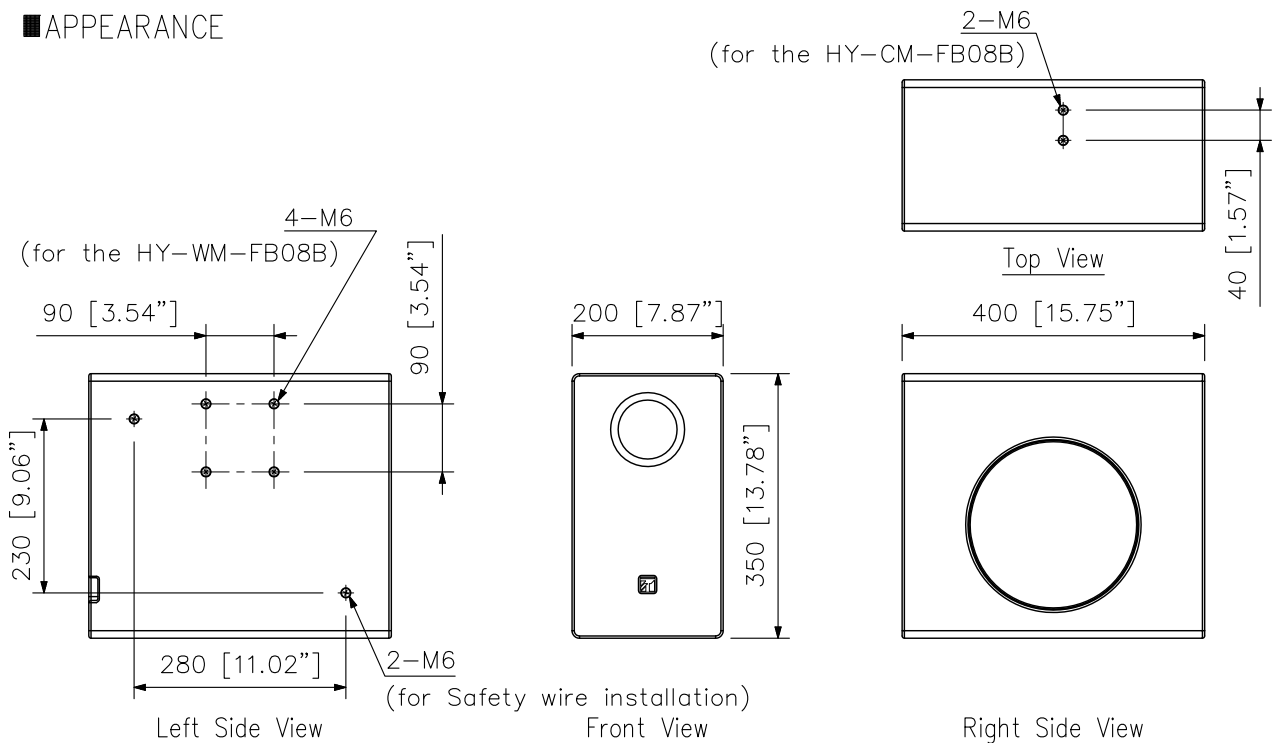

UNIT:mm SCALE:1/10

■ APPEARANCE

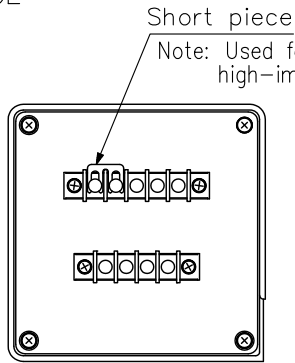

Enlarged view of Input terminal

Rear View

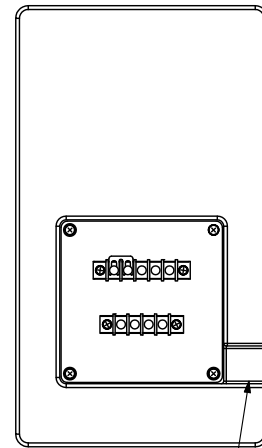

Notch

Note: The cables can be pulled out from the notch.

Circuit diagram

When using high impedance connection

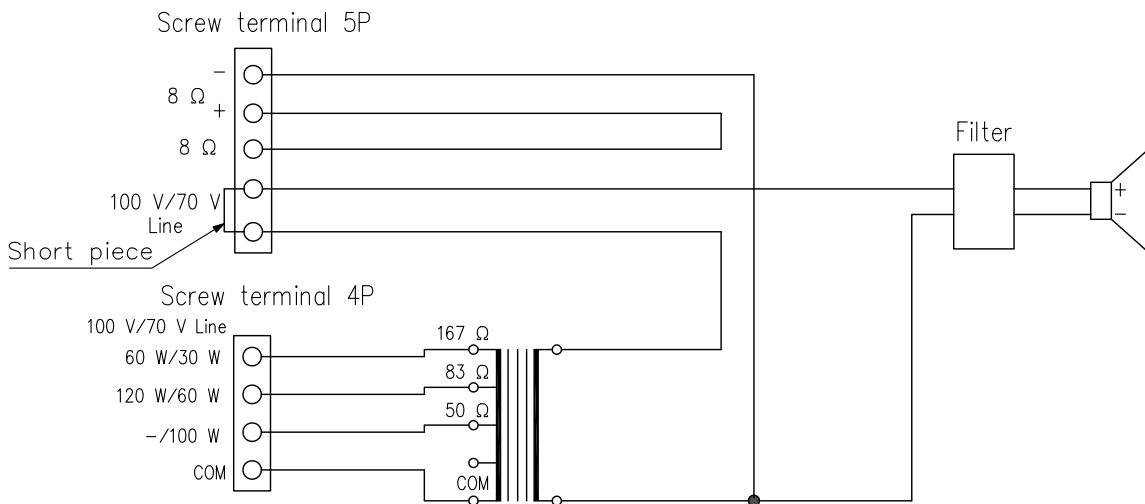

When using low impedance connection

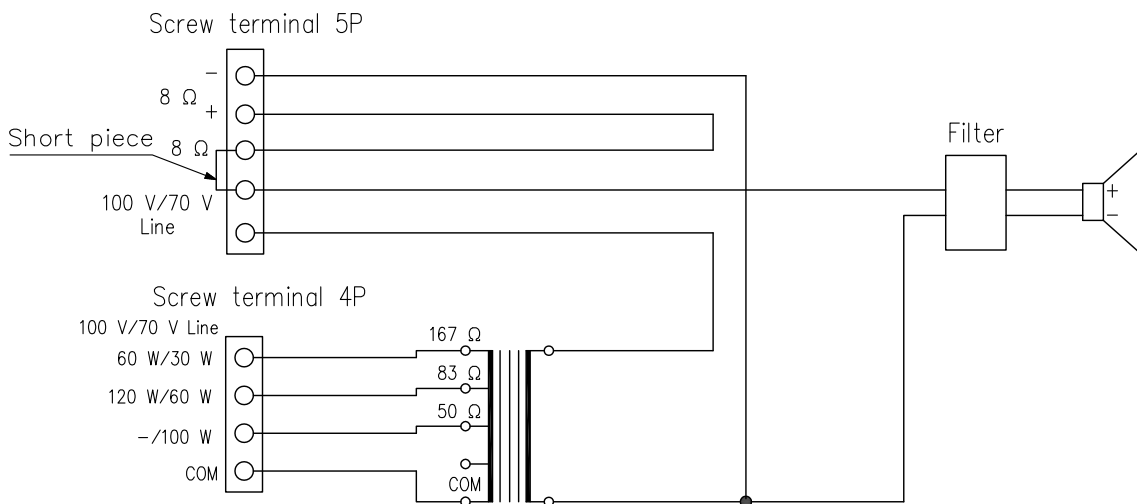

UNIT: mm SCALE: 1/6