

MIXER AMPLIFIER

A-3606D, A-3612D, A-3624D, A-3648D

(Ver. 1.06)

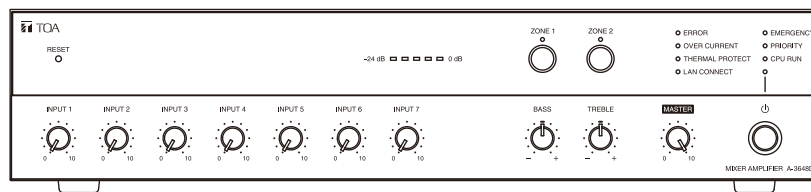

The figure represents the A-3648D.

This manual applies to the A-3600D series amplifier of which firmware version is 1.06.01 or later. The firmware version can be checked on the browser. For details, refer to the separate setup manual, which can be downloaded from the TOA DATA Library (<https://www.toa-products.com/international/>).

Thank you for purchasing TOA's Mixer amplifier.

Please carefully follow the instructions in this manual to ensure long, trouble-free use of your equipment.

TABLE OF CONTENTS

1. SAFETY PRECAUTIONS	3
2. GENERAL DESCRIPTION	5
3. FEATURES	5
4. HANDLING PRECAUTIONS	5
5. INSTALLATION PRECAUTIONS	6
6. THE DUCKER FUNCTION AND THE PRIORITY BROADCAST FUNCTION	6
7. NOMENCLATURE AND FUNCTIONS	7
Front	7
Rear	9
8. CONNECTIONS	12
8.1. Speaker Connection	12
8.2. Input Terminal Connections and Settings	13
8.3. Connecting to the Remote Master Volume Control Terminal	15
8.4. Connecting to the Power Remote Control Output Terminal	15
8.5. Connecting to the Emergency Control Output Terminal	16
8.6. Connecting to the Zone Control IN/OUT Terminal	16
8.7. Connecting to the Control Input Terminal	17
8.8. Connecting the External Equipment between the Line Output and the Power Amplifier	17
8.9. Removable Terminal Plug Connection	18
9. SETTINGS	19
9.1. Chime Tone Setting	19
9.2. Line Output Interlock Switch Setting	19
10. DUCKER DEPTH ADJUSTMENT	19
11. VOLUME ADJUSTMENT	20
12. SPEAKER ZONE SELECTION	20
13. INSTALLING TO AN EQUIPMENT RACK	21
14. CONTROL SETTINGS	21
15. PRIORITY BROADCAST FUNCTION	22
15.1. Priority Broadcast	22
15.2. Priority Broadcast Mode	22
15.3. Emergency Broadcast	24
15.4. Normal Broadcast	24
15.5. Relationship between Priority Broadcast by Control Input/Emergency Broadcast and Power On/Off	24
15.6. Factory Default Settings	25
15.7. Setting Examples and Operation Images	26
16. OPERATION IMAGE OF SPEAKER ZONE SELECTION ...	29
17. SETTINGS ON THE BROWSER	29
18. BLOCK DIAGRAM	30
19. SPECIFICATIONS	31

1. SAFETY PRECAUTIONS

- Before installation or use, be sure to carefully read all the instructions in this section for correct and safe operation.
- Be sure to follow all the precautionary instructions in this section, which contain important warnings and/or cautions regarding safety.
- After reading, keep this manual handy for future reference.

Safety Symbol and Message Conventions

Safety symbols and messages described below are used in this manual to prevent bodily injury and property damage which could result from mishandling. Before operating your product, read this manual first and understand the safety symbols and messages so you are thoroughly aware of the potential safety hazards.



WARNING

Indicates a potentially hazardous situation which, if mishandled, could result in death or serious personal injury.

When Installing the Unit

- Do not expose the unit to rain or an environment where it may be splashed by water or other liquids, as doing so may result in fire or electric shock.
- Use the unit only with the voltage specified on the unit. Using a voltage higher than that which is specified may result in fire or electric shock.
- Do not cut, kink, otherwise damage nor modify the power supply cord. In addition, avoid using the power cord in close proximity to heaters, and never place heavy objects -- including the unit itself -- on the power cord, as doing so may result in fire or electric shock.
- Be sure to ground to the safety ground (earth) terminal to avoid electric shock. Never ground to a gas pipe as a catastrophic disaster may result.
- Avoid installing or mounting the unit in unstable locations, such as on a rickety table or a slanted surface. Doing so may result in the unit falling down, causing personal injury and/or property damage.
- Since the unit is designed for indoor use, do not install it outdoors. If installed outdoors, the aging of parts causes the unit to fall off, resulting in personal injury. Also, when it gets wet with rain, there is a danger of electric shock.
- The terminals marked with the symbol ⚡ are hazardous live.
The external wiring to these terminals requires installation by an instructed person.

When the Unit is in Use

- Should the following irregularity be found during use, immediately switch off the power, disconnect the power supply plug from the AC outlet and contact your nearest TOA dealer. Make no further attempt to operate the unit in this condition as this may cause fire or electric shock.
 - If you detect smoke or a strange smell coming from the unit.
 - If water or any metallic object gets into the unit
 - If the unit falls, or the unit case breaks
 - If the power supply cord is damaged (exposure of the core, disconnection, etc.)
 - If it is malfunctioning (no tone sounds.)
- To prevent a fire or electric shock, never open nor remove the unit case as there are high voltage components inside the unit. Refer all servicing to your nearest TOA dealer.
- Do not place cups, bowls, or other containers of liquid or metallic objects on top of the unit. If they accidentally spill into the unit, this may cause a fire or electric shock.
- Do not insert nor drop metallic objects or flammable materials in the ventilation slots of the unit's cover, as this may result in fire or electric shock.
- Do not touch a power supply plug during thunder and lightning, as this may result in electric shock.



CAUTION

Indicates a potentially hazardous situation which, if mishandled, could result in moderate or minor personal injury, and/or property damage.

When Installing the Unit

- Never plug in nor remove the power supply plug with wet hands, as doing so may cause electric shock.
- When unplugging the power supply cord, be sure to grasp the power supply plug; never pull on the cord itself. Operating the unit with a damaged power supply cord may cause a fire or electric shock.

- When moving the unit, be sure to remove its power supply cord from the wall outlet. Moving the unit with the power cord connected to the outlet may cause damage to the power cord, resulting in fire or electric shock. When removing the power cord, be sure to hold its plug to pull.
- Do not block the ventilation slots in the unit's cover. Doing so may cause heat to build up inside the unit and result in fire. Also, periodically clean the ventilation slots of dust.
- Avoid installing the unit in humid or dusty locations, in locations exposed to the direct sunlight, near the heaters, or in locations generating sooty smoke or steam as doing otherwise may result in fire or electric shock.
- To avoid electric shocks, be sure to switch off the unit's power when connecting speakers.
- Be sure to follow the instructions below when rack-mounting the unit. Failure to do so may cause a fire or personal injury.
 - Install the equipment rack on a stable, hard floor. Fix it with anchor bolts or take other arrangements to prevent it from falling down.
 - When connecting the unit's power cord to an AC outlet, use the AC outlet with current capacity allowable to the unit.
 - Rack-mounting screws are not supplied with the optional MB-25B Rack mounting bracket. Prepare them that are appropriate for the equipment rack.

When the Unit is in Use

- Do not place heavy objects on the unit as this may cause it to fall or break which may result in personal injury and/or property damage. In addition, the object itself may fall off and cause injury and/or damage.
- Make sure that the volume control is set to minimum position before power is switched on. Loud noise produced at high volume when power is switched on can impair hearing.
- Do not operate the unit for an extended period of time with the sound distorting. Doing so may cause the connected speakers to heat, resulting in a fire.
- Contact your TOA dealer as to the cleaning. If dust is allowed to accumulate in the unit over a long period of time, a fire or damage to the unit may result.
- If dust accumulates on the power supply plug or in the wall AC outlet, a fire may result. Clean it periodically. In addition, insert the plug in the wall outlet securely.
- Switch off the power, and unplug the power supply plug from the AC outlet for safety purposes when cleaning or leaving the unit unused for 10 days or more. Doing otherwise may cause a fire or electric shock.

Warning: Operation of this equipment in a residential environment could cause radio interference.

- The socket-outlet shall be installed near the equipment and the plug (disconnecting device) shall be easily accessible.
- The apparatus shall be connected to a mains socket outlet with a protective earthing connection.

2. GENERAL DESCRIPTION

TOA's A-3600D Series is a PA amplifier equipped with 4 microphone inputs and 3 auxiliary inputs, and 2-channel zone selector.

In addition to each individual input volume control function, it is equipped with the following functions.

- Priority broadcast function
- Chime function
- Remote confirmation function
- Digital signal processing function

Also, the PFC circuit is provided inside.

The A-3600D Series mixer amplifier is ideal for paging announcement and BGM applications in schools, offices, and super markets.

3. FEATURES

- 4 kinds of power amplifier outputs: 60 W (A-3606D), 120 W (A-3612D), 240 W (A-3624D), and 480 W (A-3648D)
- Lightweight owing to the built-in digital power amplifier unit
- Emergency broadcast and priority broadcast activated by way of the control input (contact)
- Voice detection function that allows the priority broadcast to be activated by voice
- Priority setting function
- Remote confirmation function that allows you to confirm the unit's status through the web browser using a PC
- Switchable speaker output
 - A-3606D: 8 to 16 Ω or 100 V line
 - A-3612D, A-3624D, A-3648D: 4 to 16 Ω or 100 V line
- Zone selection buttons for making broadcasts to 2 zones
- Electronically-balanced 4 microphone inputs (MIC 1 to MIC 4) with input setting switches
- Fine sound adjustment possible by connecting a signal processor like an equalizer between the line output and the power amplifier input
- Bass and treble tone control knobs
- Output level meter
- Master volume control knob to simultaneously adjust all input levels
- Remotely controllable master volume
- Built-in chime unit (1-note chime, 2-note chime, and ascending 4-note chime)
- Equipped with the following signal processing functions:
 - FBS (Feedback suppression function), Equalizer (3 points), Gate, Software volume, Limiter, and Ducker

4. HANDLING PRECAUTIONS

- In this system, settings and control of the unit are performed on a PC via LAN (Local area network). It is not possible to perform them via the Internet.
- Some operations differ depending on this unit's power ON/OFF state. The table below shows the relationship between the power ON/OFF state and the corresponding operation.

Power state	LED lighting state		Normal broadcast		Priority broadcast/ Emergency broadcast	Web access
		CPU RUN	From Speaker output	From Recording output		
Not energized	Unlit	Unlit	Disabled	Disabled	Disabled	Disabled
Energized (Power turned OFF)	Unlit	Lit	Disabled	Disabled	Occasionally possible (Power is temporarily turned ON.)	Enabled
Energized (Power turned ON)	Lit	Lit	Enabled	Enabled	Enabled	Enabled

- When adjusting the volume using a single frequency signal, input its signal to BUS 2. If you input it to BUS 1, the volume may be lowered due to the FBS function of this unit.

5. INSTALLATION PRECAUTIONS

- The supplied power supply cord is designed for exclusive use with the unit. Never use it with other equipment.
- Install the unit in a well-ventilated environment so that temperature inside the unit will not rise.
- When installing the unit on the desk, keep the unit over 10 cm away from objects that may obstruct air flow as shown below.
- When installing the unit in an equipment rack, mount perforated panels. See "INSTALLING TO AN EQUIPMENT RACK" on p. 21.

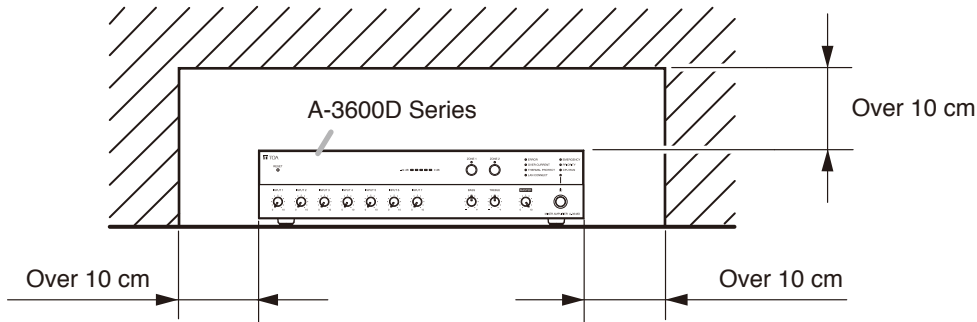

6. THE DUCKER FUNCTION AND THE PRIORITY BROADCAST FUNCTION

This unit is provided with Ducker function and Priority broadcast function that decrease the output level of other broadcasts while a specific broadcast is being made.

A Ducker function refers to the function to place a priority order between the audio signal groups divided into 2 groups. Use this function to make a simple usage such as to decrease the BGM level when making microphone announcement while the BGM broadcast is in progress.

For the details of the Ducker function, See "DUCKER DEPTH ADJUSTMENT" on p. 19.

A Priority broadcast function is the function to assign one of 6 priority levels to each broadcast content. Use this function to make a complicated usage compared with the Ducker function such as to select the audio signal to mute.

For the details of the Priority broadcast function, See "PRIORITY BROADCAST FUNCTION" on p. 22.

7. NOMENCLATURE AND FUNCTIONS

[Front]

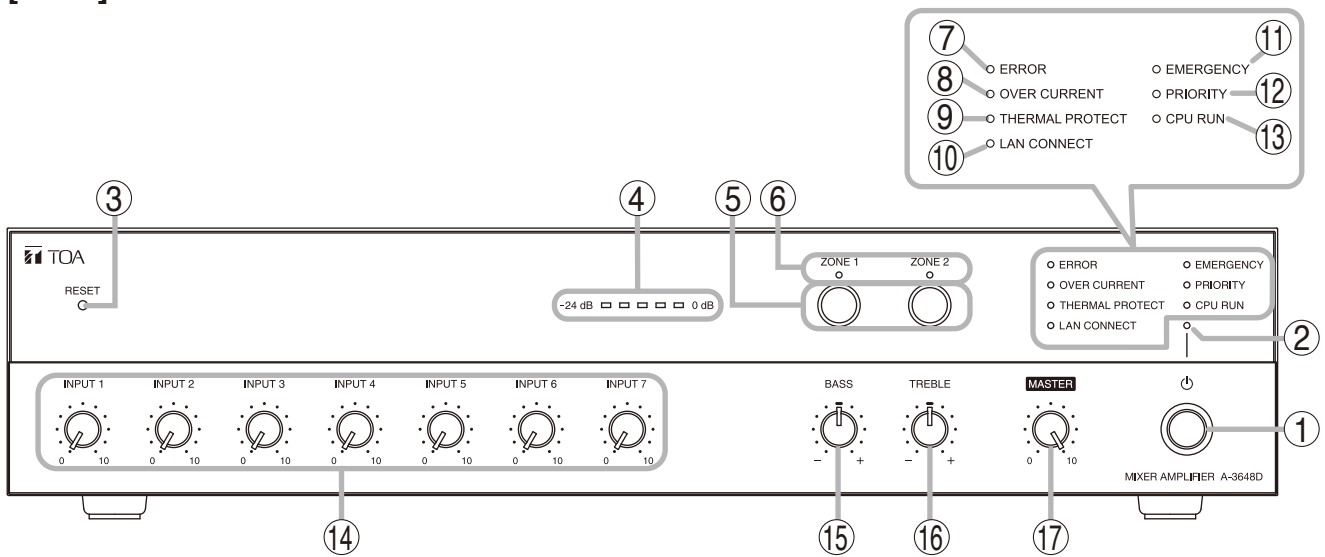

The figure represents the A-3648D.

1. Power switch

Press this switch to turn on the power. To turn off the power, press this switch again.

Note

Operation of the power switch is disabled while the priority broadcast or the emergency broadcast is in progress.

(See "PRIORITY BROADCAST FUNCTION" on p. 22.)

2. Power indicator (Green)

Lights when the power is switched on and goes off when it is switched off.

3. Reset key

Press this key for 1 second or more to reset the unit.

Use a fine-tipped object to press in this switch.

Note

Perform the following steps before pressing the Reset key.

- Turn all volume knobs fully counterclockwise to minimize the volume value.
- Confirm that both the Priority broadcast indicator (12) and the Emergency broadcast indicator (11) are unlit.
- Press the Power switch (1) to turn it OFF.

4. LED level meter (Green x 3, Orange x 1, Red x 1)

Displays the output level.

Adjust each volume control knob for an appropriate output sound so that the red indicator does not light.

Operating the unit while the red indicator remains lit causes the sound quality to degrade.

5. Zone selection buttons

Select the broadcast zones.

Pressing this button places the corresponding zone in selected state, allowing the signal output from the rear-mounted Speaker output terminal (31). Pressing it again cancels the zone selected state, disabling the signal output from the rear-mounted Speaker output terminal (31).

Notes

- These buttons are effective only when the Output impedance setting switch (32) is set to 100 V line (high impedance).
- While the Zone control input terminal (33) is closed, the operation of the Zone selection button is invalid even if you press it.

6. Zone indicator (Green)

The indicator corresponding to the selected zone lights.

Notes

- These indicators work only when the Output impedance setting switch (32) is set to 100 V line (high impedance).
- When the power is energized, the indicator corresponding to the selected zone lights as the CPU is running regardless of whether the power is switched on or off.

7. Error indicator (Red)

Lights when the unit's internal abnormality has occurred.

8. Overcurrent protection indicator (Red)

Lights while the overcurrent protection circuit is operating if overcurrent flows through the speaker output.

9. Thermal protection indicator (Red)

Lights while the internal protection circuit is operating.

10. Network connection confirmation indicator (Green)

An indicator to identify the unit using a web browser.

- Flashes for 5 seconds when the identification confirmation is performed using a web browser.
- Flashes 3 times when the unit is started up.
- Lights when in the manual mode.

(See the separate setup manual, which can be downloaded from the TOA DATA Library (<https://www.toa-products.com/international/>.)

11. Emergency broadcast indicator (Red)

Lights while the emergency broadcast is in progress. (See "PRIORITY BROADCAST FUNCTION" on p. 22.)

12. Priority broadcast indicator (Green)

Lights while the priority broadcast is in progress. (See "PRIORITY BROADCAST FUNCTION" on p. 22.)

13. CPU running indicator (Green)

Lights while the CPU is running.

Note

As long as the power is energized, this indicator lights since the CPU is running regardless of whether the power is switched on or off.

14. Volume control knobs for Inputs 1 through 7

Adjust the volume values of the Inputs 1 through 7.* Rotate each knob clockwise to increase the volume value and counterclockwise to decrease it. (See "VOLUME ADJUSTMENT" on p. 20.)

15. Bass control knob

Rotate the knob clockwise to boost the bass and counterclockwise to cut it.

Setting the knob at the center makes the frequency characteristic flat.

16. Treble control knob

Rotate the knob clockwise to boost the treble and counterclockwise to cut it.

Setting the knob at the center makes the frequency characteristic flat.

17. Master volume control knob

Adjusts all the volume levels simultaneously.*

Rotate the knob clockwise to increase the whole volume level and counterclockwise to decrease it.

(See "VOLUME ADJUSTMENT" on p. 20.)

* As this unit is equipped with a gate function (explained below) that works on the input signal, the audio output may be intermitted if the input signal is small. In such a case, increase the volume with the volume control knob for the corresponding input, then adjust the overall volume using the master volume control knob.

Note that the gate function is a function that allows input signals to be passed through, attenuated, or cut depending on the input signal level. Gate function settings cannot be changed.

[Rear]

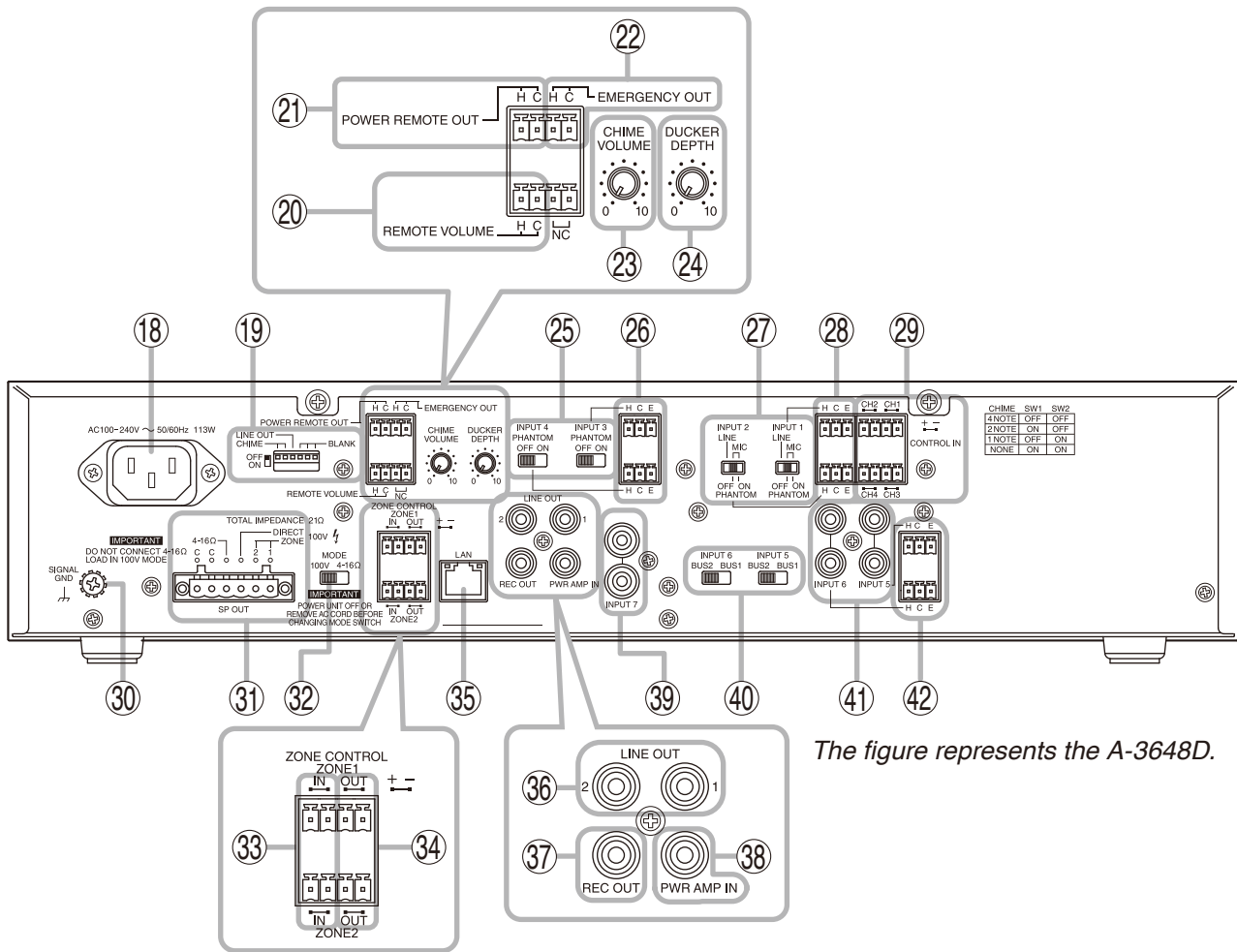

The figure represents the A-3648D.

18. AC inlet

Connect the supplied power cord to this receptacle.

⚠ WARNING

Be sure to use the supplied power cord. Using any other power cord may cause electric shock.

19. DIP switch

- **Switches 1 and 2 (Chime tone setting switch)**
Set the chime tone to be used.
(See "Chime Tone Setting" on p. 19.)
- **Switch 3 (Line output interlock switch)**
Sets an interlock between the zone selection and the line output.
(See "Line Output Interlock Switch Setting" on p. 19.)
- **Switches 4 through 6**
Not used.

20. Remote master volume control terminal

Short-circuit current: 10 mA or less, open voltage : 35 V DC or less, removable terminal block (3.50 mm, 4 pins)
Sound volume can be adjusted by connecting the 10 kΩ B-taper potentiometer.
(See "Connecting to the Remote Master Volume Control Terminal" on p. 15.)

21. Power remote control output terminal

Open collector output, withstand voltage: 30 V DC or less, current: 25 mA or less, removable terminal block (3.50 mm, 4 pins)
An output terminal that can be used for remote control of other equipment. Operates in synchronization with the unit's power ON/OFF. When the unit's power is on, it is activated.

22. Emergency control output terminal

Open collector output, withstand voltage: 30 V DC or less, current: 25 mA or less, removable terminal block (3.50 mm, 4 pins)
An output terminal that can be used for remote control of other equipment.
It is activated during the emergency broadcast made from the unit.

23. Chime volume control knob

Adjusts the chime volume.
 Rotate the knob clockwise to increase the chime volume and counterclockwise to decrease it.
 Minimizing the volume level makes the chime silent.

24. Ducker depth control knob

Adjusts the automatically attenuated level of the sound volume on the BUS 2 while the broadcast is being made using the BUS 1.
 Rotate the knob clockwise to increase the attenuation on the BUS 2 and counterclockwise to decrease it. (See "DUCKER DEPTH ADJUSTMENT" on p. 19.)

25. Input setting switches (Inputs 3 and 4)

Set whether or not to supply phantom power to the microphones connected to Inputs 3 and 4 (26).

Tip

Phantom power is a 24 V DC.

26. Input terminals (Inputs 3 and 4)

-60 dB*1, 600 Ω, electronically-balanced, removable terminal block (3.81 mm, 3 pins)
 Input terminals dedicated for microphones

27. Input setting switches (Inputs 1 and 2)

Set the input sensitivity level (LINE or MIC) of the Inputs 1 and 2 (28). When switched to the microphone input, set the phantom power to ON or OFF.

Switch position		Input specification at the time of setting
MIC	PHANTOM ON	-60 dB*1, 600 Ω, phantom power ON
	PHANTOM OFF	-60 dB*1, 600 Ω, phantom power OFF
LINE		-20 dB*1, 600 Ω, with no phantom power

Tip

Phantom power is a 24 V DC.

28. Input terminals (Inputs 1 and 2)

-20 dB*1 (LINE)/-60 dB*1 (MIC), 600 Ω, electronically-balanced, removable terminal block (3.81 mm, 3 pins)
 Input sensitivity can be switched either to the Line input sensitivity or the Microphone input sensitivity.
 The input sensitivity can be changed with the Input setting switch (27).

29. Control input terminals (Control inputs 1 through 4)

Short-circuit current: 10 mA or less, open voltage: 35 V DC or less, Removable terminal block (3.81 mm, 4 pins)
 Input the control signals for controlling the priority broadcast.

While the terminals are closed, the corresponding trigger of the priority broadcast becomes input state.

30. Functional ground terminal

Noise may be generated when external equipment is connected to the unit. In this case, connect this terminal to the functional ground terminal of the external equipment, and the noise may be reduced.

Note

This ground is not for protective ground.

31. Speaker output terminal

Removable terminal block (5.00 mm, 6 pins)
 Outputs the audio signals of the MAIN output or power amplifier output. (See "BLOCK DIAGRAM" on p. 30.)
 When the Zone 1 is selected, audio signals are output from the Zone 1 speaker output terminal. In the same manner, when the Zone 2 is selected, audio signals are output from the Zone 2 speaker output terminal.
 When set to High impedance, audio signals are always output from the Direct speaker output terminal regardless of the Zone selection button setting.

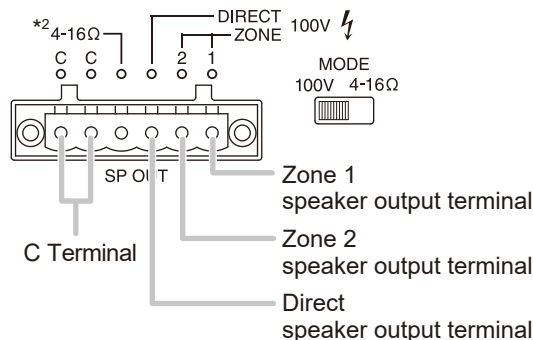

The table below shows the specifications of each output.

	A-3606D	A-3612D	A-3624D	A-3648D
Rated output	60 W	120 W	240 W	480 W
Low impedance	8 to 16 Ω	4 to 16 Ω		
High impedance (100 V line)	170 Ω	83 Ω	42 Ω	21 Ω

Notes

- Never use the low impedance and high impedance terminals simultaneously. Doing so may cause damage to the unit or the peripheral equipment.
- Never make connection to low impedance terminal when the Output impedance setting switch (32) is set to 100 V.

Tip

To change impedance between high and low, use the Output impedance setting switch (32).

32. Output impedance setting switch

Changes the speaker output impedance either to low or high.

100 V: High impedance

4 – 16 Ω*2: Low impedance

Notes

- Make sure that the power is switched OFF before changing this switch setting. Change cannot be performed when the power is on.
- The impedance remains as it is even if you change the switch setting when the power is ON. However, the impedance will change when you turn the power ON again after turning the power OFF.

33. Zone control input terminals

Short-circuit current: 10 mA or less, open voltage: 35 V DC or less, Removable terminal block (3.81 mm, 4 pins)

Input the control signals for selecting zones. While the terminals are closed, the corresponding zone becomes in selected state, disabling operation of the Zone selection button(5).

Notes

- Zone control is effective only when the Output impedance setting switch (32) is set to 100 V line (high impedance).
- The zone selected state is maintained even if this terminal is opened after being closed while the zone is being selected with the Zone selection button (5).

By giving precedence to the control by this terminal, you can change the setting so as to release the zone selection status when the terminal is opened after being closed.

(See the separate setup manual, which can be downloaded from the TOA DATA Library (<https://www.toa-products.com/international/>).

34. Zone control output terminals

Open collector output, withstand voltage: 30 V DC or less, current: 25 mA or less, Removable terminal block (3.81 mm, 4 pins),

Output terminals for using the remote control of other equipment. The terminal corresponding to the selected zone is closed.

Note

Zone control is effective only when the Output impedance setting switch (32) is set to 100 V line (high impedance).

35. Network terminal

RJ45 jack

Connect this terminal to the 100BASE-TX network using a STP Category 5 or greater straight through cable. A PC can be connected directly to this terminal without using a hub.

36. Line output jacks 1 and 2

0 dB*1, 600 Ω, unbalanced type, RCA pin jack x 2

Can be interlocked with the zone selection state.

Signals are output from the Line output jacks 1

and 2 regardless of the zone selection when the Line output selection interlock is set to OFF. With the Line output interlock set to ON, the signals are output from the Line output jack 1 when the Zone 1 is selected, and from the Line output jack 2 when the Zone 2 is selected.

Use the DIP switch (19) to make the interlock setting.

37. Recording output jack

0 dB*1, 600 Ω, unbalanced type, RCA pin jack

Outputs the audio signals of the SUB output. (See "BLOCK DIAGRAM" on p. 30.)

Used to record the broadcast contents by connecting the external recording device to this jack.

38. Power amplifier input jack

0 dB*1 600 Ω, unbalanced type, RCA pin jack

Input the output of the signal processor or other devices connected to the Line output jack. (See "Connecting the External Equipment between the Line Output and the Power Amplifier" on p. 17.)

Connecting a pin plug to this jack disconnects the power amplifier section from the preamplifier section inside the unit.

39. Input 7 jacks

–20 dB*1, 10 kΩ, unbalanced type, RCA pin jack x 2

Input jacks dedicated for LINE

40. BUS setting switches

Set which to send the audio signals input from the Inputs 5 and 6 to the BUS 1 or 2 using the slide switches.

(See "BLOCK DIAGRAM" on p. 30.)

Output destination selection switch	Usable input terminal
BUS 1	Input terminal dedicated for BUS 1 (Removable terminal block)
BUS 2	Input terminal dedicated for BUS 2 (RCA pin jack x 2)

41. Input terminals dedicated for BUS 2

(Inputs 5 and 6)

–20 dB*1, 10 kΩ, unbalanced type, RCA pin jack x 2

To use these jacks, select "BUS 2" with the BUS setting switches (40).

(See "BLOCK DIAGRAM" on p. 30)

42. Input terminals dedicated for BUS 1

(Inputs 5 and 6)

–60 dB*1, 600 Ω, electronically-balanced, removable terminal block (3.81 mm, 3 pins)

To use these terminals, select "BUS 1" with the BUS setting switches (40).

(See "BLOCK DIAGRAM" on p. 30.)

*1 0 dB = 1 V

*2 In case of the A-3606D: 8 – 16 Ω

8. CONNECTIONS

External cable wiring must be only carried out by qualified and trained personnel.

8.1. Speaker Connection

For cable wiring to the removable terminal block, refer to p. 18.

Notes

- Never make connection to both 4 – 16 Ω* (low impedance) and 100 V line (high impedance) terminals simultaneously.
- Never make connection to 4 – 16 Ω* terminal when the Output impedance setting switch is set to 100 V.

Tips

- Either C terminal can be used for connection.
- Recommended speaker cable is IV or HIV cable with thickness described below.

Solid copper cable: $\varnothing 0.32 - 2.0$ mm
 Stranded copper cable: 0.05 – 3.3 mm (AWG 30 – 12)

A-3606D/3612D/3624D/3648D

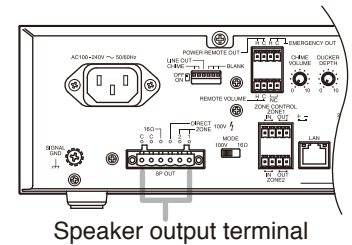

[Low impedance connection]

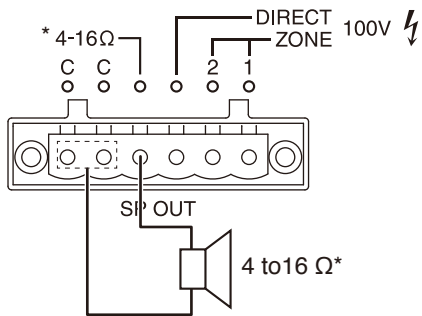

[High impedance connection]

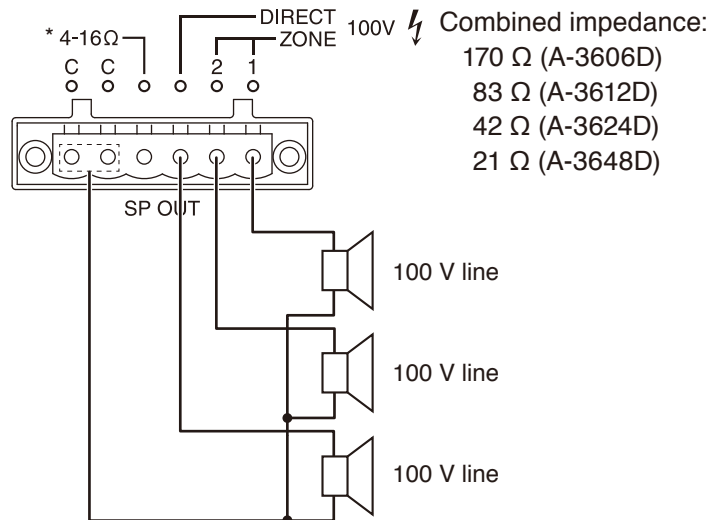

For the audio output at high impedance application setting, refer to "32. Output impedance setting switch" on p. 11.

* In case of the A-3606D: 8 – 16 Ω

8.2. Input Terminal Connections and Settings

8.2.1. Connections

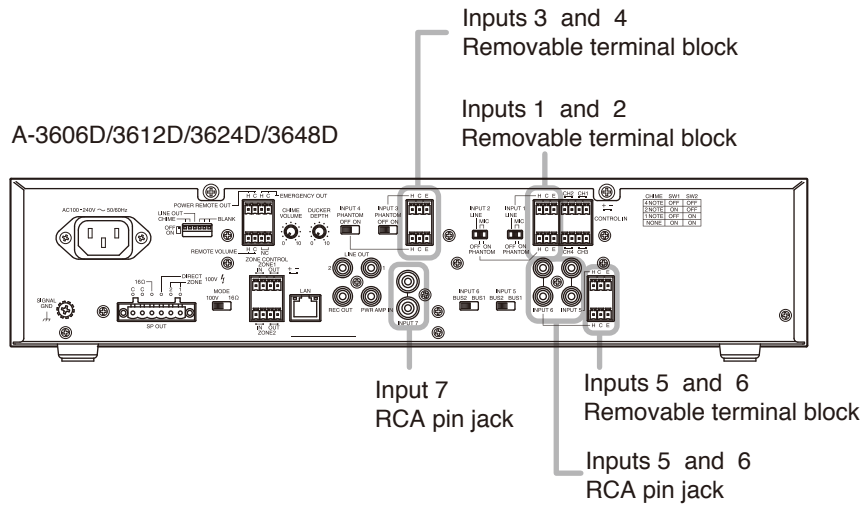

The terminal used for each of the Inputs 5 and 6 differs depending on the BUS setting switch (Refer to the next page.).

Connect the cable to the correct terminal according to the input terminal to use.

[Inputs 1 through 6 (Inputs 5 and 6 connections are for routing to BUS 1)]

(When connecting a 2-core shielded cable)

(When connecting a single core shielded cable)

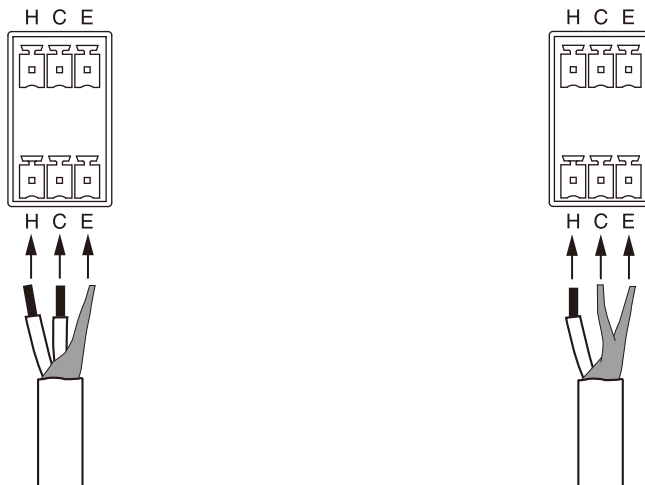

For cable wiring to the removable terminal plug, refer to p. 18.

[Inputs 5 through 7 (Inputs 5 and 6 connections are for routing to BUS 2)]

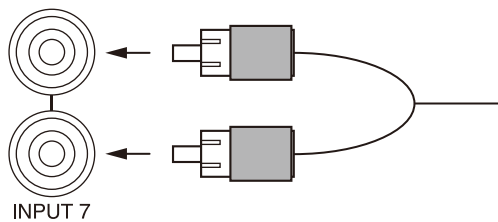

8.2.2. Inputs 1 through 6 settings

Each of Inputs 1 through 6 has its own setting switch corresponding to each input. Perform their settings as shown below as needed.

[Inputs 1 and 2]

Set the sound source level to connect and whether or not to use the phantom power when the microphone input is selected.

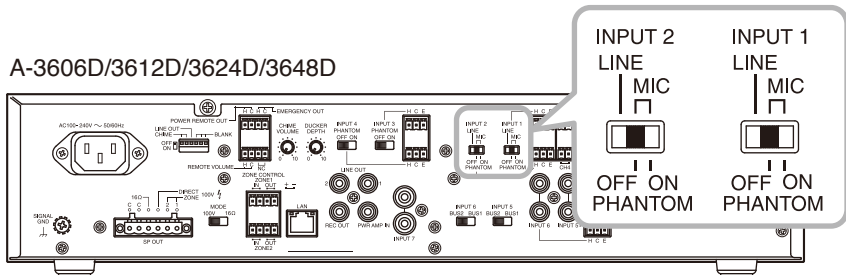

Input sound source	Switch position	Input specification
Line level	LINE	-20 dB*, 600 Ω
Microphone level, phantom power not required	MIC – PHANTOM OFF (Factory-preset)	-60 dB*, 600 Ω
Microphone level, phantom power required	MIC – PHANTOM ON	-60 dB*, 600 Ω

[Inputs 3 and 4]

Set whether or not to use phantom power on the Inputs 3 and 4 (dedicated microphone inputs).

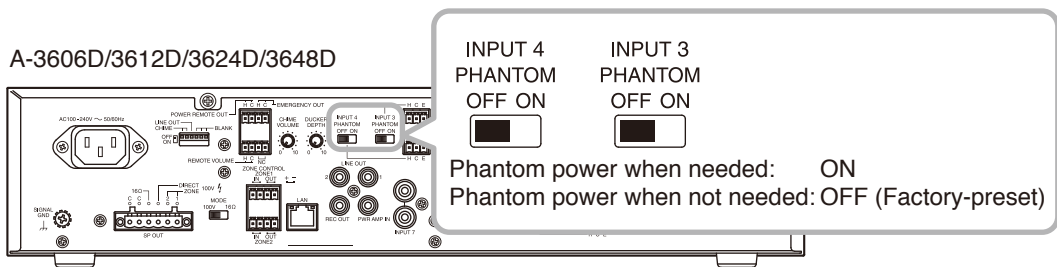

Input specifications: -60 dB*, 600 Ω, electronically balanced

[Inputs 5 and 6]

Set which to send the input audio signals to BUS 1 or BUS 2.
Operation when the ducker function works is different between BUS 1 and BUS 2.
(Refer to "DUCKER DEPTH ADJUSTMENT" on p. 19.)

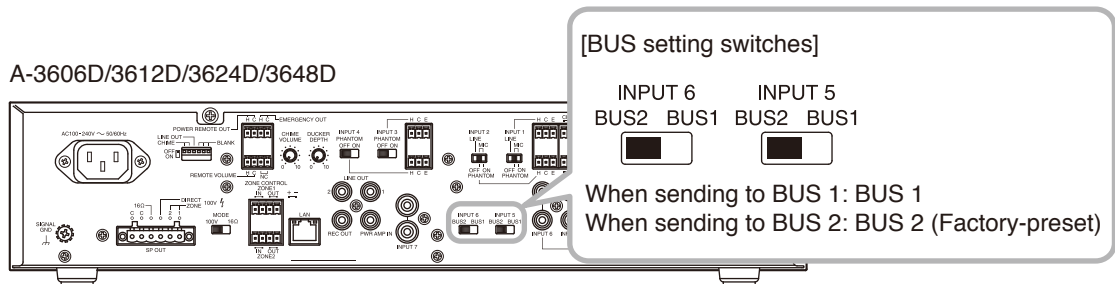

Input specifications: -60 dB*, 600 Ω, electronically balanced, removable terminal block (3.81 mm, 3 pins) (when outputting to BUS 1)
-20 dB*, 10 kΩ, unbalanced, RCA pin jack (when outputting to BUS 2)

* 0 dB = 1 V

8.3. Connecting to the Remote Master Volume Control Terminal

You can adjust the volume level by remote control when an external volume control is connected to the unit. To remotely control the volume level, adjust the unit's volume level with the master volume control knob in advance. The level adjusted with the master volume control knob is the maximum volume level that you can remotely control.

For cable wiring to the removable terminal plug, refer to p. 18.

Note

- Never set the master volume control knob to the minimum position. If set to the minimum, no sound is output even if you maximize the volume level through this terminal. (Refer to "VOLUME ADJUSTMENT" on p. 20.)
- The unit may malfunction due to the influence of noises generated from power lines or lighting equipment such as fluorescent lamps. In such cases, use shielded cables for wiring to the unit, or install the wiring cables fully away from the power lines and fluorescent lamps.

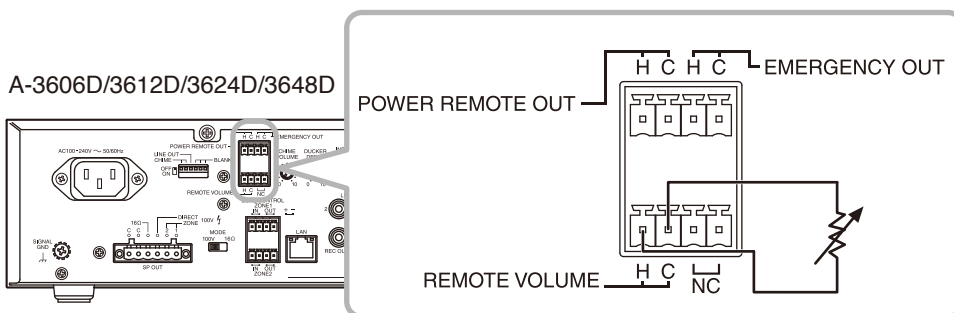

Connectable volume controller: 10 kΩ B-taper potentiometer

8.4. Connecting to the Power Remote Control Output Terminal

Use this terminal when remotely controlling other equipment. This terminal is activated when the unit is turned ON.

For cable wiring to the removable terminal plug, refer to p. 18.

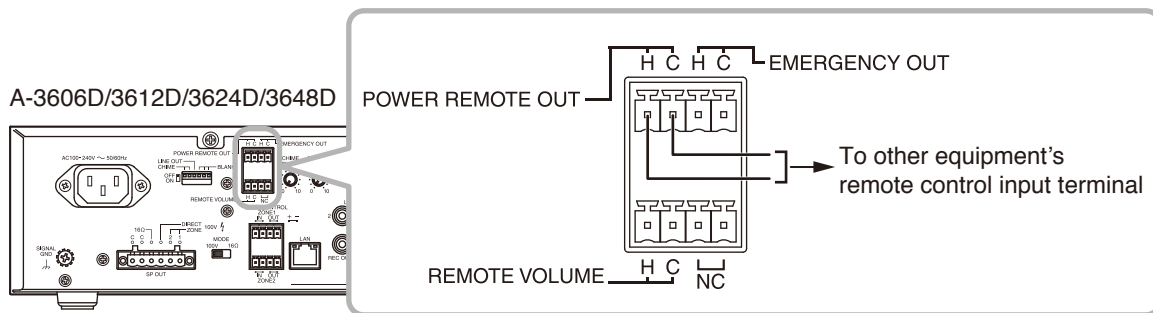

Output specifications: Open collector output, withstand voltage: 30 V DC or less, current: 25 mA or less

8.5. Connecting to the Emergency Control Output Terminal

Use this terminal when remotely controlling other equipment. This terminal is activated while the emergency broadcast is in progress from this unit.
 For cable wiring to the removable terminal plug, refer to p. 18.

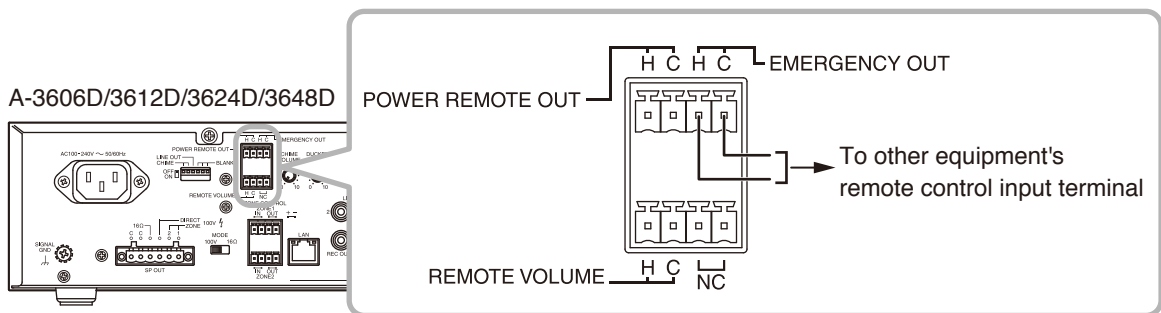

Output specifications: Open collector output, withstand voltage: 30 V DC or less, current: 25 mA or less

8.6. Connecting to the Zone Control IN/OUT Terminal

Zone can be selected by a control signal (make contact).
 These terminals also output a control signal (logic low) when the zone is in selected state. They can be used for remotely controlling other equipment.

Note

Zone control is effective only when the Output impedance setting switch is set to 100 V line (high impedance).

For cable wiring to the removable terminal plug, refer to p. 18.

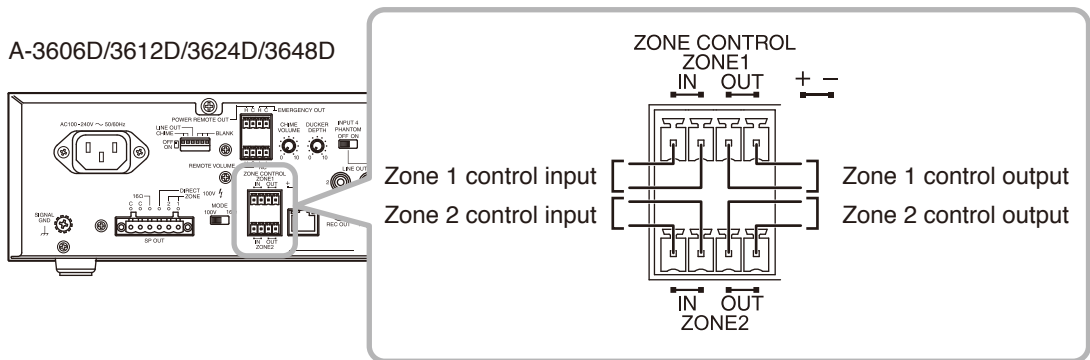

Control input signal specifications: Short-circuit current: 10 mA or less, open voltage: 35 V DC or less
 Control output signal specifications: Open collector output, withstand voltage: 30 V DC or less, current: 25 mA or less

8.7. Connecting to the Control Input Terminal

Priority broadcast can be controlled by inputting the contact signal to these terminals. For the priority setting, refer to the separate setup manual, which can be downloaded from the TOA DATA Library (<https://www.toa-products.com/international/>).

For cable wiring to the removable terminal plug, refer to p. 18.

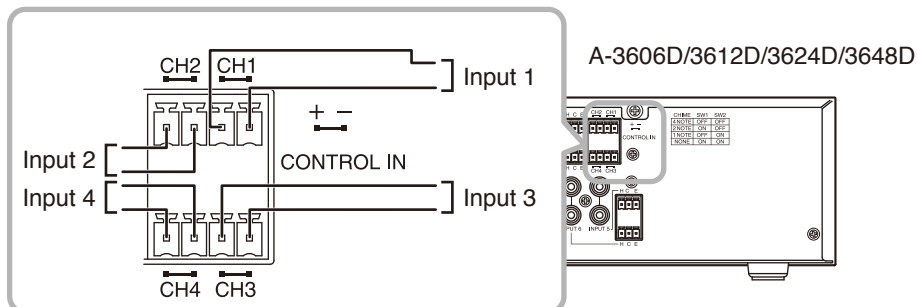

Input signal specifications: Short-circuit current: 10 mA or less, open voltage: 35 V DC or less

8.8. Connecting the External Equipment between the Line Output and the Power Amplifier

Appropriate sound can be obtained by connecting a signal processor like an equalizer or limiter between the unit's preamplifier section (Line output jack) and the power amplifier section (Power amplifier input jack).

Notes

- When using the signal processor, be sure to turn OFF the unit's line output interlock switch.
- Inserting a pin plug into the unit's power amplifier input jack disconnects the preamplifier section from the power amplifier section inside the unit.

Tip

Either Line output 1 or 2 can be used.

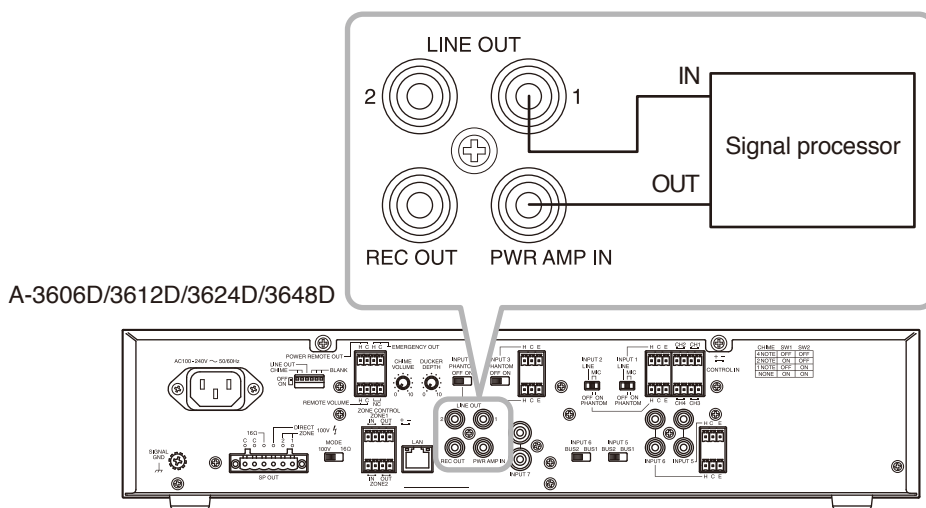

Line output specifications: 0 dB*, 600 Ω, unbalanced, RCA pin jack
 Power amplifier input specifications: 0 dB*, 600 Ω, unbalanced, RCA pin jack

* 0 dB = 1 V

8.9. Removable Terminal Plug Connection

Step 1. Wiring the supplied removable terminal plug.

- 1-1. Loosen the terminal screws to insert the wire.
- 1-2. Tighten the terminal screws.
Ensure that the wire does not break free when pulled. If the wire does pull free, repeat the connection procedure from the start.

Step 2. Insert the wired terminal plug into the corresponding terminal block in the unit's rear panel.

Step 3. Only when the fixing screw is inserted, tighten the fixing screw.

Notes

- Do not reverse **Steps 1 and 2** above. Poor contact may result if force is applied to the unit's internal circuit board pins while the terminal screws are being tightened.
- When detaching the terminal plug, pull it straight out. Pulling it out at an angle may cause the terminal plug or terminal block to break.

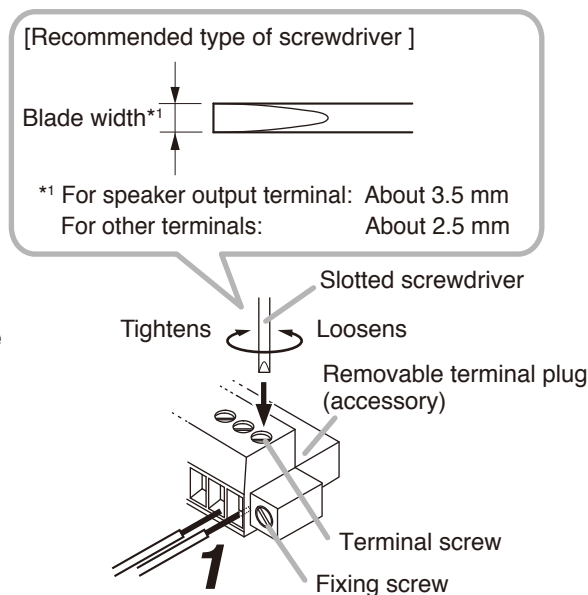

Tips

- Applicable cable size

	For speaker output terminal	For other terminals
Conductor cross-section area	0.05 – 3.3 mm ²	0.08 – 2.0 mm ²
AWG	AWG 30 – 12 or equivalent	AWG 28 – 14 or equivalent

- Cable sheath to trim

Solid cable and stranded cable

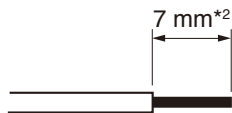

Shielded cable

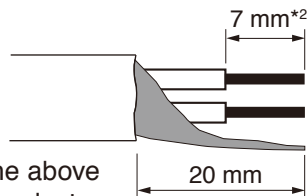

*2 Expose 8 mm or more when using the above ferrule terminal, and cut off an extra conductor protruding from the sleeve.

Note

Avoid soldering stranded or shielded cable, as contact resistance may increase when the cable is tightened and the solder is crushed, possibly resulting in an excessive rise in joint temperatures.

- When connecting 2 cables or a shielded cable to a single terminal, use a ferrule terminal with an insulation sleeve to crimp the cables because such cable conductors could become loose.

(1) Recommended ferrule terminals for signal cables

(made by Phoenix Contact)

Unit: mm

	Model Number	a	b	l ₁	l ₂
①	AI 0,34-8 TQ	2	0.8	12.5	8
②	AI 0,5-8 WH	2.5	1.1	14	8

(2) Recommended ferrule terminals for speaker cables

(made by Phoenix Contact)

Unit: mm

	Model Number	a	a ₁	a ₂	b	l ₁	l ₂
③	AI 1,5-8 BK	3.4	—	—	1.8	14	8
④	AI-TWIN 2 x 1,5-8 BK	—	6.6	3.6	2.3	16	8

Crimping tool: CRIMPFOX 10S (made by Phoenix Contact)

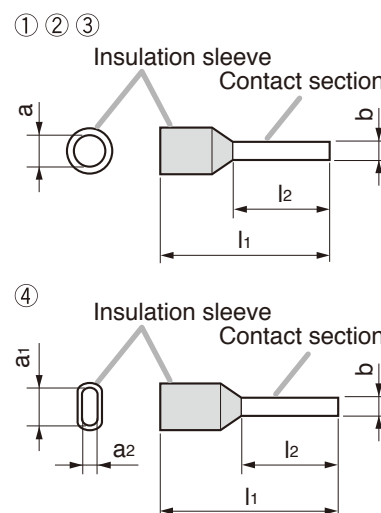

9. SETTINGS

9.1. Chime Tone Setting

Set the chime tone to use with the DIP switches 1 and 2.

A-3606D/3612D/3624D/3648D

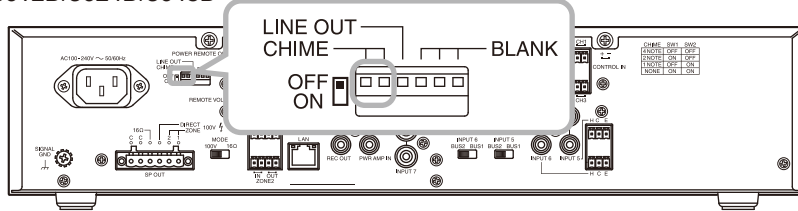

Chime tone to use	Switch 1	Switch 2	Switch's figures
4-note (Factory-preset)	OFF	OFF	OFF ON
2-note	ON	OFF	OFF ON
1-note	OFF	ON	OFF ON
Not used	ON	ON	OFF ON

Notes

- Regardless of whether the priority broadcast function (p. 22) has been set or not, when the chime tone is set to use, input signals to the BUS 2 are muted while the chime is sounding. Even if the chime is silent with the chime volume set to the minimum, the input signal muting will be executed.
- When set to “Not used,” input signals to the BUS 2 are not muted.

9.2. Line Output Interlock Switch Setting

Set the interlock between zone selection and line output using Switch 3 of the DIP switch.

A-3606D/3612D/3624D/3648D

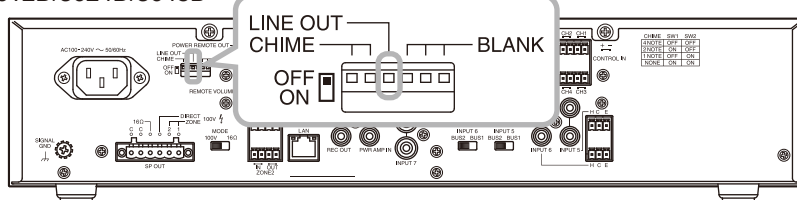

- OFF: Signals are output from the Line output jacks 1 and 2 regardless of zone selection. (Factory-preset)
 ON: Signals are output from the Line output jack 1 when the Zone 1 is selected and from the Line output jack 2 when the Zone 2 is selected.

10. DUCKER DEPTH ADJUSTMENT

The unit is equipped with Ducker function. When broadcast is made through BUS 1, the volume level of the audio signals input to BUS 2 is automatically attenuated.

Each input is sent to either BUS 1 or BUS 2 as shown below.

Input No.	Input destination
Inputs 1 through 4	BUS 1
Inputs 5 and 6	BUS 1 or BUS 2 selectable
Input 7	BUS 2

Attenuation amount can be adjusted with the Ducker depth control knob. Rotate the knob clockwise to increase the attenuation amount and counterclockwise to decrease it.

When signals stop entering BUS 1, the volume level on BUS 2 automatically returns to its original level. (Refer to "BLOCK DIAGRAM" on p. 30.)

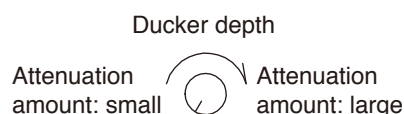
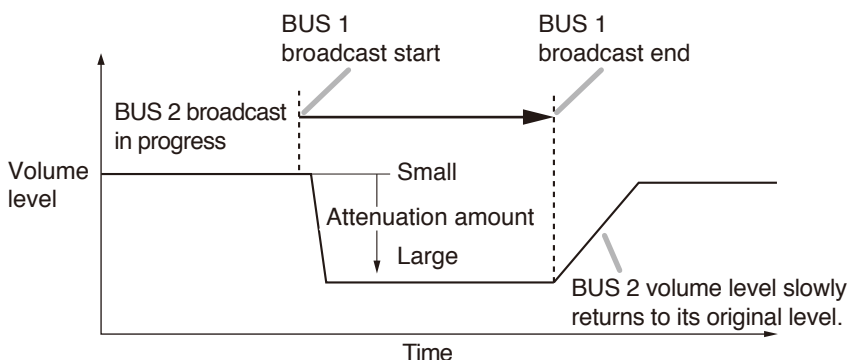

Note
When the knob is rotated fully counterclockwise, the volume level of BUS 2 signals such as BGM will not decrease.

11. VOLUME ADJUSTMENT

The unit's volume value can be adjusted in 4 steps with the different means as described below.

- Inputs 1 to 7 volume control knobs
- Software master volume control
- Remote master volume control
- Master volume control knob

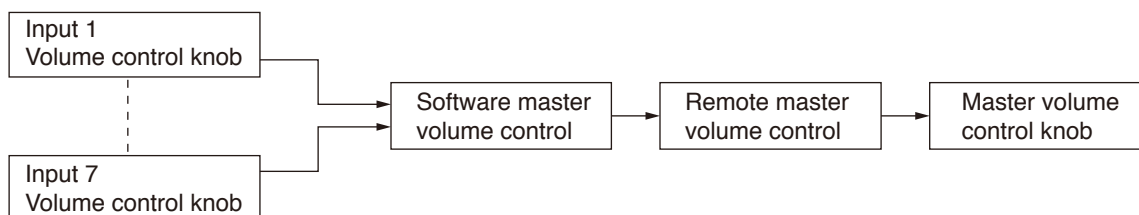

If any one of the volume controls is set to the minimum, no sound is output even if other volume control is set to the maximum. If you intend to adjust the volume value with the Software master volume control*1 or the Remote master volume control (see p. 15), adjust the volume value using the master volume control knob in advance. The value adjusted with the master volume control knob is the adjustable upper limit.

When set to the Emergency broadcast, the broadcast is made at the maximum level regardless of the set values of the master volume, software master volume, and remote master volume*2. Also, the chime is sounded at the maximum volume, and the characteristics of the EQ, tone control, and bass control are made flat.

The front-mounted emergency broadcast indicator lights during emergency broadcast, making the Emergency control output terminal closed.

*1 Adjust the Software master volume control using the browser. For details, refer to the separate setup manual, which can be downloaded from the TOA DATA Library (<https://www.toa-products.com/international/>).

*2 Volume control knobs for each input remain effective.

12. SPEAKER ZONE SELECTION

Pressing the unit's front-mounted Zone 1 selection switch or inputting the control signal to the Zone 1 control input terminal allows the Zone 1 indicator to light and the broadcast to be output from the speakers connected to the rear-mounted Zone 1 speaker output terminal. Concurrently, the control signal is output from the Zone 1 control output terminal.

Operation in the case of Zone 2 is the same as above.

See p. 29 for the operation image of the speaker zone selection.

Note

Speaker zone control is effective only when the Output impedance setting switch (p. 11) is set to 100 V line (high impedance).

When set to High impedance, audio signals are always output from the Direct speaker output terminal regardless of the Zone selection button setting.

13. INSTALLING TO AN EQUIPMENT RACK

When installing the unit to an equipment rack, remove the four plastic feet screwed on the unit's base as shown below.

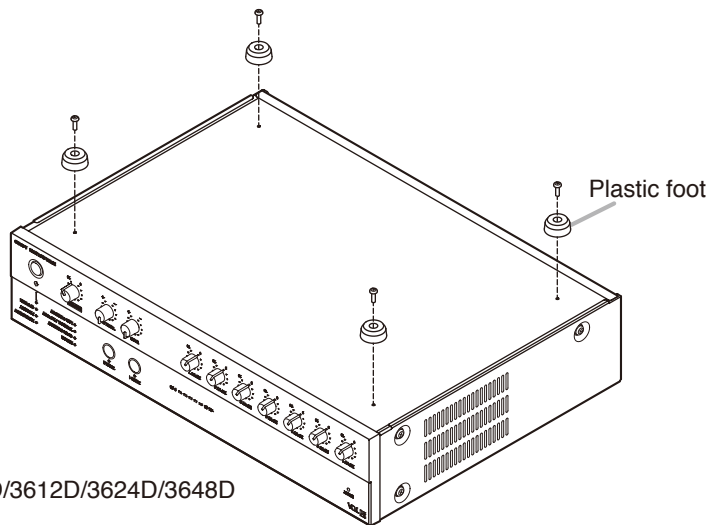

A-3606D/3612D/3624D/3648D

When installing the unit to an equipment rack, use the optional MB-25B Rack mounting bracket.



CAUTION

Rack-mounting screws are not supplied with the optional MB-25B Rack mounting bracket. Prepare them that are appropriate for the equipment rack.

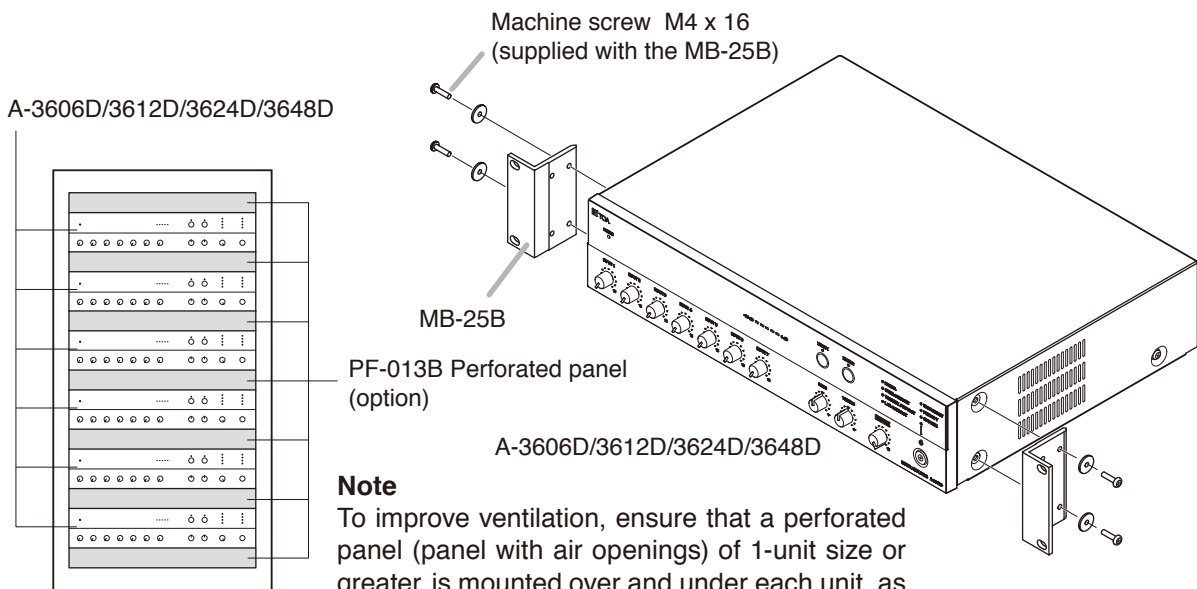

A-3606D/3612D/3624D/3648D

Machine screw M4 x 16
(supplied with the MB-25B)

MB-25B

PF-013B Perforated panel
(option)

A-3606D/3612D/3624D/3648D

Note

To improve ventilation, ensure that a perforated panel (panel with air openings) of 1-unit size or greater is mounted over and under each unit, as well as on the top and at the bottom of the rack.

14. CONTROL SETTINGS

Output levels are adjustable with individual volume controls. For music play or announcements, adjust the corresponding volume control so that the red indicator doesn't light. Note that the sound quality is downgraded when the red indicator remains lit.

To prevent the accidental change of the settings of input volume and tone (Bass and Treble) controls, remove their knobs after setting them to the desired position and attach the supplied volume control covers instead.

A-3606D/3612D/3624D/3648D

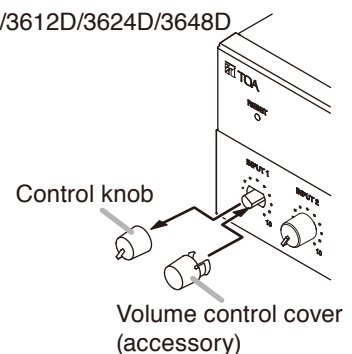

Control knob

Volume control cover
(accessory)

15. PRIORITY BROADCAST FUNCTION

Perform the settings related to the priority broadcast using a web browser. For details, refer to the separate setup manual which can be downloaded from the TOA DATA Library (<https://www.toa-products.com/international/>).

15.1. Priority Broadcast

Priority broadcast function refers to a function that mutes the designated audio signal by means of the control signal or audio signal as a trigger when it is input.

One of 6 priority levels can be assigned to the signal that works as a trigger. When multiple triggers are input, the one with higher priority assigned takes precedence.

The Priority broadcast indicator on the front panel is lit while the priority broadcast is in progress.

Two modes are available for the priority broadcast: Standard mode and Manual mode. The unit will start in Standard mode when energized.

The mode can be changed using the web browser. For details, refer to the separate setup manual, which can be downloaded from the TOA DATA Library (<https://www.toa-products.com/international/>).

15.2. Priority Broadcast Mode

15.2.1. Standard mode

When making the priority broadcast in Standard mode, the following 6 signals can be used as triggers to activate the priority broadcast.

- Control inputs 1 through 4 (contact)
- Audio detections 1 and 2 (audio input to Inputs 1 and 2)

The table below shows the difference between the control input and the audio detection.

	Signal that functions as a trigger	Input that can be muted	Settable broadcast	Power on in power off state	Use of chime
Control input	Contact inputs (Contacts 1 through 4)	Inputs 1 through 7	Emergency broadcast Priority broadcast	Enabled	Enabled
Audio detection	Audio inputs (Inputs 1 and 2)	Input other than the one set to audio detection	Priority broadcast	Disabled	Disabled

You can edit the following items related to the priority broadcast on the browser for each trigger. Designated audio signals can be muted in the case of normal broadcast that is not activated by any trigger. For details, refer to the separate setup manual, which can be downloaded from the TOA DATA Library (<https://www.toa-products.com/international/>).

Item	Setting contents
Valid/Invalid	When set to "Valid," priority broadcast will start if the corresponding trigger is input.
Priority level	<ul style="list-style-type: none"> • You can set 6 different levels of priority. However, you cannot assign the same priority level to the multiple triggers. It means only 1 priority level can be assigned to a single trigger. • A trigger with the highest priority level assigned can be set to emergency broadcast. <p>Note Emergency broadcast can be assigned only to the control input.</p> <ul style="list-style-type: none"> • If a higher-priority trigger is input while a priority broadcast is in progress, the higher-priority broadcast takes precedence, overriding the current broadcast. • If a lower-priority trigger is input while a priority broadcast is in progress, the lower-priority trigger is ignored.
Chime ON/Chime OFF	<p>Sounds the set chime when the trigger set to "Chime ON" is input. However, no chime sounds when the trigger is ignored.</p> <p>Note Chime can be assigned only to the control input.</p>
Input to be muted/ Input not to be muted	<p>Mutes the input set to "Input to be muted" when the priority broadcast is activated.</p> <p>Note It may take a few seconds before the volume level returns to the original level after mute is released.</p>

Note

- If the lower priority trigger that is so set to sound a chime is kept applied when the higher priority trigger stops, the chime will not sound even when the broadcast is switched to the lower priority one.
- Regardless of whether the priority level has been set or not, input signals to the BUS 2 are muted while the chime is sounding.

15.2.2. Manual mode

The designated audio signal can be muted from the browser in Manual mode. Use this mode to check the device operation. (See the separate setup manual*.) The unit's Network connection confirmation indicator lights in the manual mode.

* Can be downloaded from the TOA DATA Library (<https://www.toa-products.com/international/>).

15.3. Emergency Broadcast

You can set the priority broadcast with the highest priority level to the emergency broadcast. When set to the Emergency broadcast, the broadcast is made at the maximum level regardless of the set values of the master volume, software master volume, and remote master volume*. Also, the chime is sounded at the maximum volume, and the characteristics of the EQ, tone control, and bass control are made flat. The front-mounted emergency broadcast indicator lights during emergency broadcast, making the Emergency control output terminal closed.

* Volume control knobs for each input remain effective.

Note

Priority broadcast activated by way of the audio detection cannot be set to emergency broadcast.

15.4. Normal Broadcast

The broadcast that stays in the state where the unit's power is ON with no trigger input is referred to as the Normal broadcast.

Note

Chime at normal broadcast cannot be set to ON.

15.5. Relationship between Priority Broadcast by Control Input/Emergency Broadcast and Power On/Off

[When this unit is in power OFF state]

- This unit is turned ON when the Priority or Emergency broadcast starts.
- Even if you attempt to turn OFF the power* while the Priority or Emergency broadcast is in progress, this operation is invalid.
- This unit will be turned OFF when the Priority or Emergency broadcast terminates. However, if the higher priority broadcast by audio detection overlaps, the power will be turned OFF after this priority broadcast by audio detection is terminated.

[When this unit is in power ON state]

- This unit remains in power ON state regardless whether the Priority or Emergency broadcast starts or terminates.
- Even if you attempt to turn OFF the power* while the Priority or Emergency broadcast is in progress, this operation is invalid.

* Refers to the operation of pressing this unit's front-mounted power switch or clicking the Power ON checkbox to uncheck on the browser screen.

15.6. Factory Default Settings

[Factory default setting list]

Trigger	Priority level	Emergency	Chime	Audio inputs							Status
				1	2	3	4	5	6	7	
Control input 1		Set	🔊	●	🔊	🔊	🔊	🔊	🔊	🔊	Valid
Control input 2	↑ High ↓ Low	—	●	🔊	●	🔊	🔊	🔊	🔊	🔊	Valid
Control input 3		—	●	●	●	●	●	●	●	●	Valid
Control input 4		—	🔊	●	●	●	●	●	●	●	Valid
Audio detection (Input 1)		—	🔊	●	🔊	🔊	🔊	🔊	🔊	🔊	Invalid
Audio detection (Input 2)	—	🔊	🔊	●	🔊	🔊	🔊	🔊	🔊	🔊	Invalid
Normal broadcast	—	—	—	●	●	●	●	●	●	●	—

Notes

- Inputs marked "🔊" in the Chime field are set to "Chime OFF," while those marked "●" are set to "Chime ON."
- Inputs marked "🔊" in the Audio input field are set to "Muted," while those marked "●" are set to "Not muted."
- The unit starts up in Standard mode.
- Gray cells indicate the set contents in them cannot be changed.
- Dash marks "-" show that nothing can be set.

Shown below are the operations by the factory default.

[Operation image]

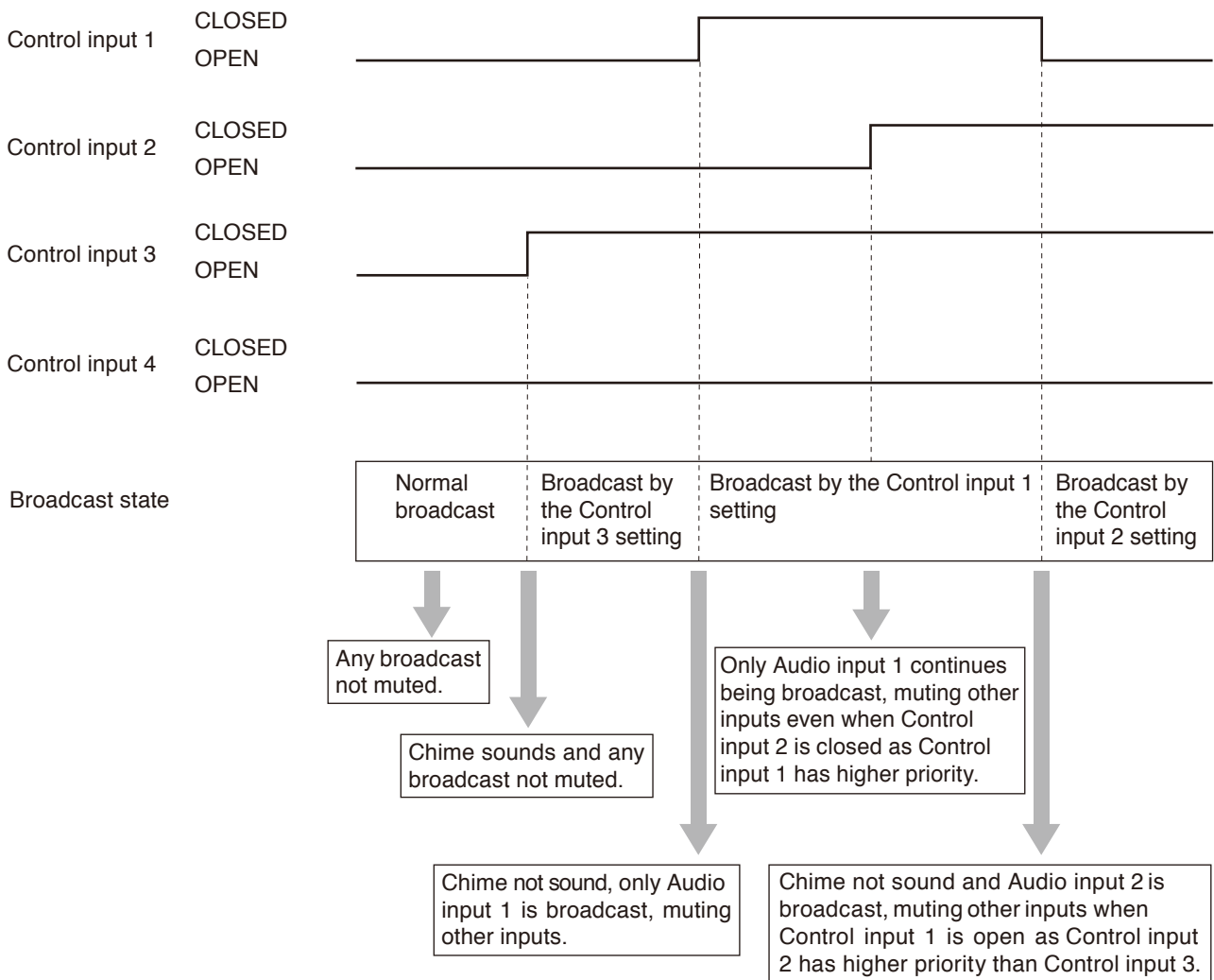

15.7. Setting Examples and Operation Images

15.7.1. If the power is ON while being energized

[Setting list]

Trigger	Priority level	Emergency	Chime	Audio inputs							Status	
				1	2	3	4	5	6	7		
Control input 2		Not set	●	🔇	●	🔇	🔇	🔇	🔇	🔇	🔇	Valid
Audio detection (Input 1)	High	—	🔇	●	🔇	🔇	🔇	🔇	🔇	🔇	🔇	Valid
Control input 1		—	●	🔇	🔇	🔇	🔇	●	🔇	🔇	Valid	
Control input 3		—	●	●	●	●	●	●	●	●	Invalid	
Control input 4		—	🔇	●	●	●	●	●	●	●	Invalid	
Audio detection (Input 2)	Low	—	🔇	🔇	●	🔇	🔇	🔇	🔇	🔇	Invalid	
Normal broadcast	—	—	—	🔇	🔇	🔇	🔇	🔇	🔇	🔇	—	

Notes

- Inputs marked "🔇" in the Chime field are set to "Chime OFF," while those marked "●" are set to "Chime ON."
- Inputs marked "🔇" in the Audio input field are set to "Muted," while those marked "●" are set to "Not muted."
- Gray cells indicate the set contents in them cannot be changed.
- Dash marks "—" show that nothing can be set.

[Operation image]

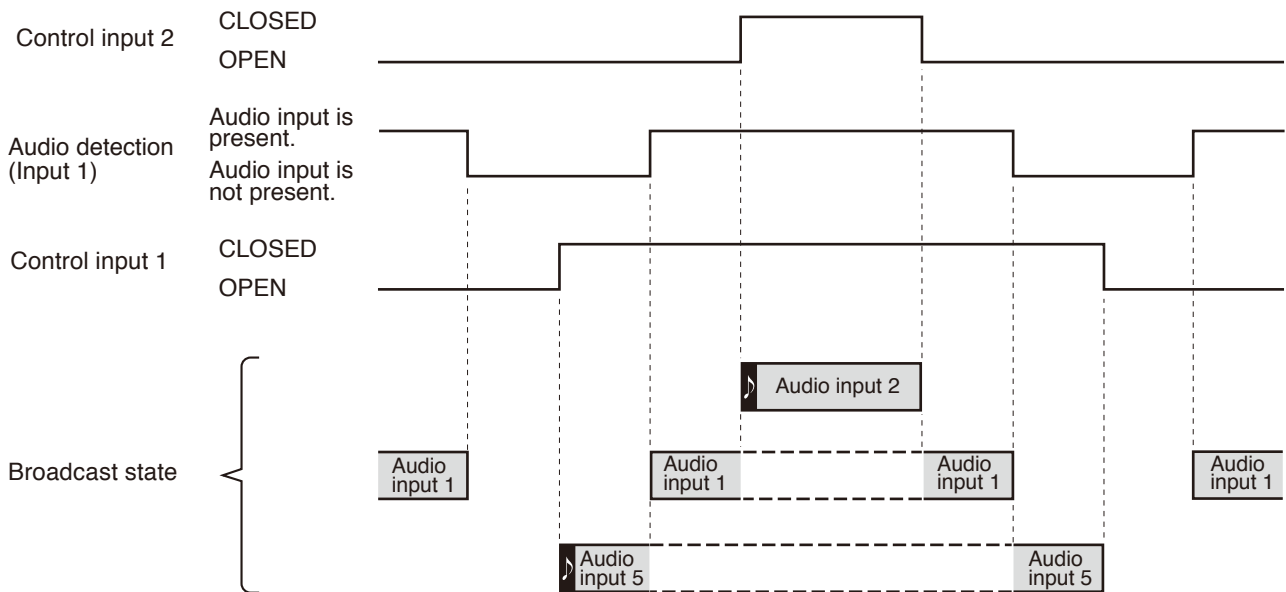

Notes

- Symbol "🔇" represents a startup chime of broadcast.
- Gray box " " represents the broadcast currently being output.
- Box with a dashed line " " represents the state that broadcast is activated but not being output because the priority level is low.

15.7.2. If the power is OFF while being energized

Even when the power is OFF while being energized, it is kept ON as long as the control input is closed. While the power is ON, the priority-assigned audio signals are output according to the priority levels. The power is not turned ON even if there is an audio detection input while the power is OFF.

[Setting list]

Trigger	Priority level	Emergency	Chime	Audio inputs							Status	
				1	2	3	4	5	6	7		
Control input 2		Not set	●	🔇	●	🔇	🔇	🔇	🔇	🔇	🔇	Valid
Audio detection (Input 1)	High	—	🔇	●	🔇	🔇	🔇	🔇	🔇	🔇	🔇	Valid
Control input 1		—	●	🔇	🔇	🔇	🔇	●	🔇	🔇	Valid	
Control input 3		—	●	●	●	●	●	●	●	●	Invalid	
Control input 4		—	🔇	●	●	●	●	●	●	●	Invalid	
Audio detection (Input 2)	Low	—	🔇	🔇	●	🔇	🔇	🔇	🔇	🔇	Invalid	
Normal broadcast	—	—	—	🔇	🔇	🔇	🔇	🔇	🔇	🔇	—	

Notes

- Inputs marked "🔇" in the Chime field are set to "Chime OFF," while those marked "●" are set to "Chime ON."
- Inputs marked "🔇" in the Audio input field are set to "Muted," while those marked "●" are set to "Not muted."
- Gray cells indicate the set contents in them cannot be changed.
- Dash marks "—" show that nothing can be set.

[Operation image]

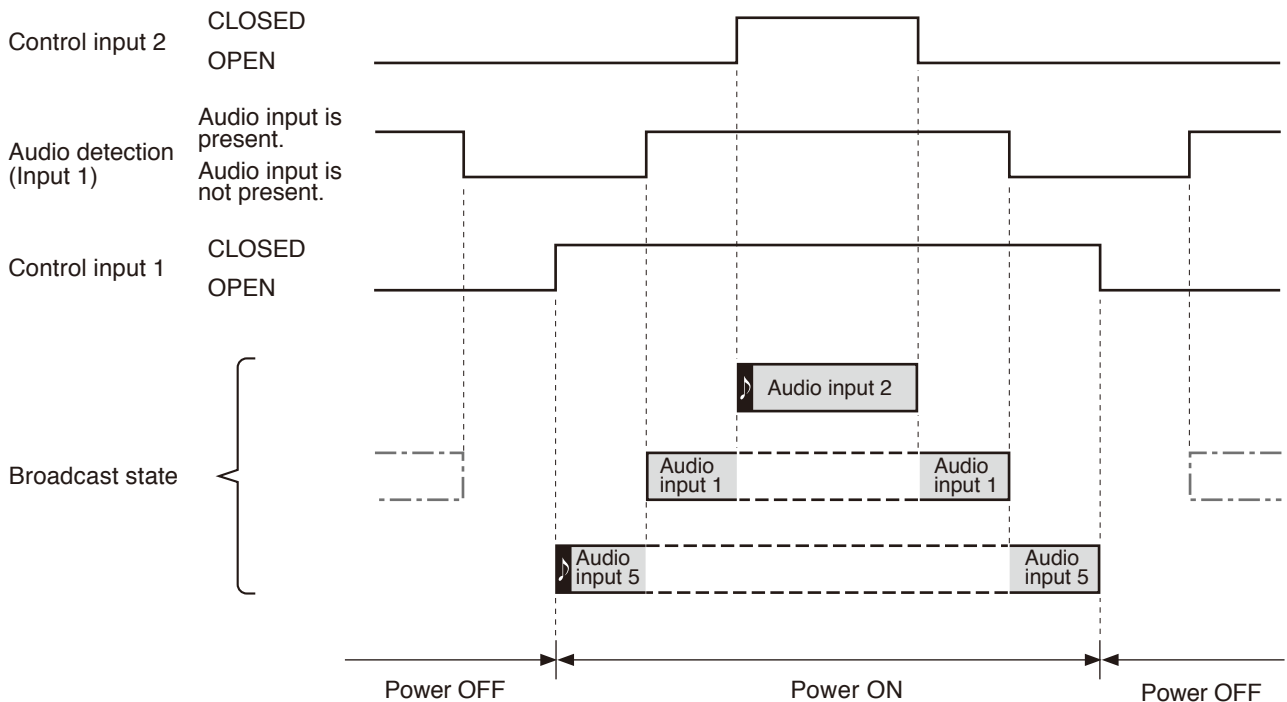

Notes

- Symbol "🔔" represents a startup chime of broadcast.
- Gray box " [] " represents the broadcast currently being output.
- Box with a dashed line " [] " represents the state that broadcast is activated but not being output because the priority level is low.
- Box with a dash-dotted line " [] " represents the state that broadcast is not being output because the power is off though an audio detection trigger has been input.

Only in the following case, the power is ON in the period that only the audio detection input is present.
 When the control input and the audio detection input with higher priority overlap, the power remains ON until the audio detection input is terminated after all control inputs are opened.

[Setting list]

Trigger	Priority level	Emergency	Chime	Audio inputs							Status
				1	2	3	4	5	6	7	
Audio detection (Input 1)		-	🔊	●	🔊	🔊	🔊	🔊	🔊	🔊	Valid
Control input 2		-	●	🔊	●	🔊	🔊	🔊	🔊	🔊	Valid
Control input 1		-	●	🔊	🔊	🔊	🔊	●	🔊	🔊	Valid
Control input 3		-	●	●	●	●	●	●	●	●	Invalid
Control input 4		-	🔊	●	●	●	●	●	●	●	Invalid
Audio detection (Input 2)	-	-	🔊	🔊	●	🔊	🔊	🔊	🔊	🔊	Invalid
Normal broadcast	-	-	-	🔊	🔊	🔊	🔊	🔊	🔊	🔊	-

Notes

- Inputs marked "🔊" in the Chime field are set to "Chime OFF," while those marked "●" are set to "Chime ON."
- Inputs marked "🔊" in the Audio input field are set to "Muted," while those marked "●" are set to "Not muted."
- Gray cells indicate the set contents in them cannot be changed.
- Dash marks "-" show that nothing can be set.

[Operation image]

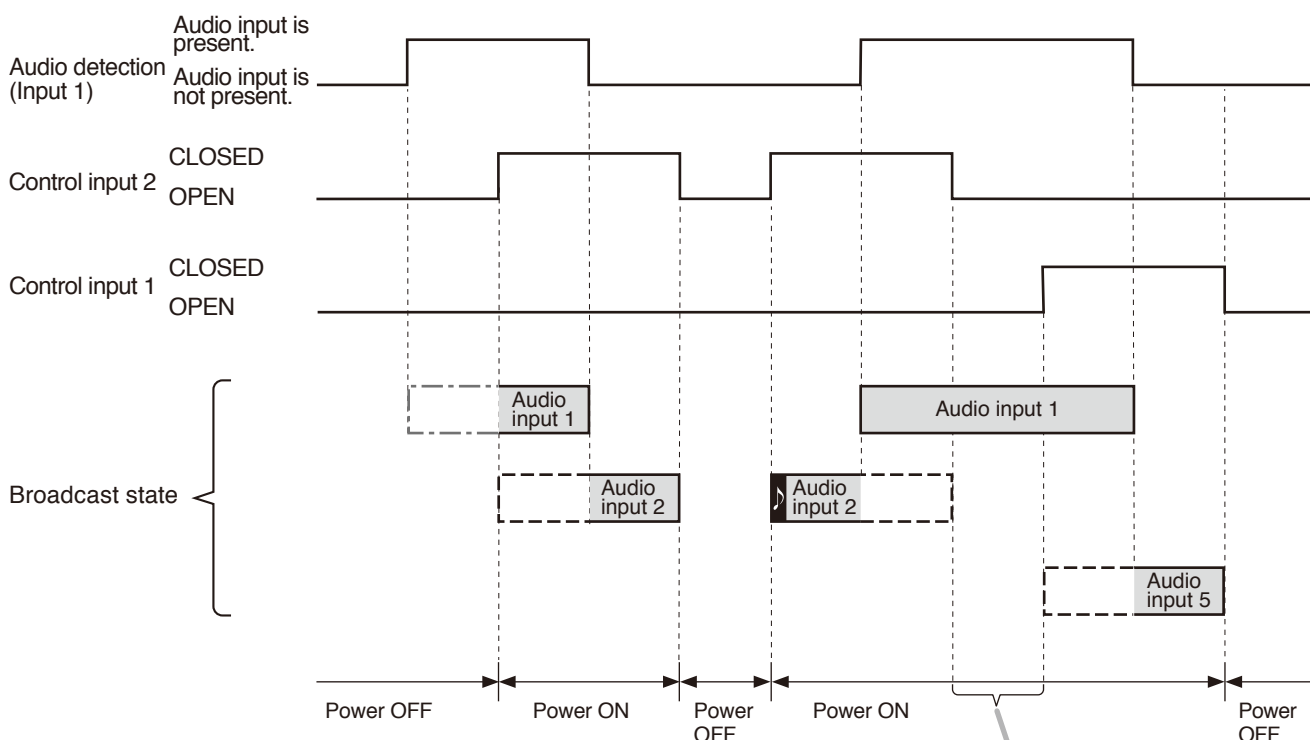

Notes

- Symbol "🔊" represents a startup chime of broadcast.
- Gray box " [gray box] " represents the broadcast currently being output.
- Box with a dashed line " [dashed box] " represents the state that broadcast is activated but not being output because the priority level is low.
- Box with a dash-dotted line " [dash-dotted box] " represents the state that broadcast is not being output because the power is off though an audio detection trigger has been input.

16. OPERATION IMAGE OF SPEAKER ZONE SELECTION

Speaker zone selection operation using the zone selection button and the zone control input terminal differs depending on the settings.

For the detailed settings, read the separate setup manual. You can download it from the TOA DATA Library site (<https://www.toa-products.com/international/>).

[Operation chart of the device's zone selection status]

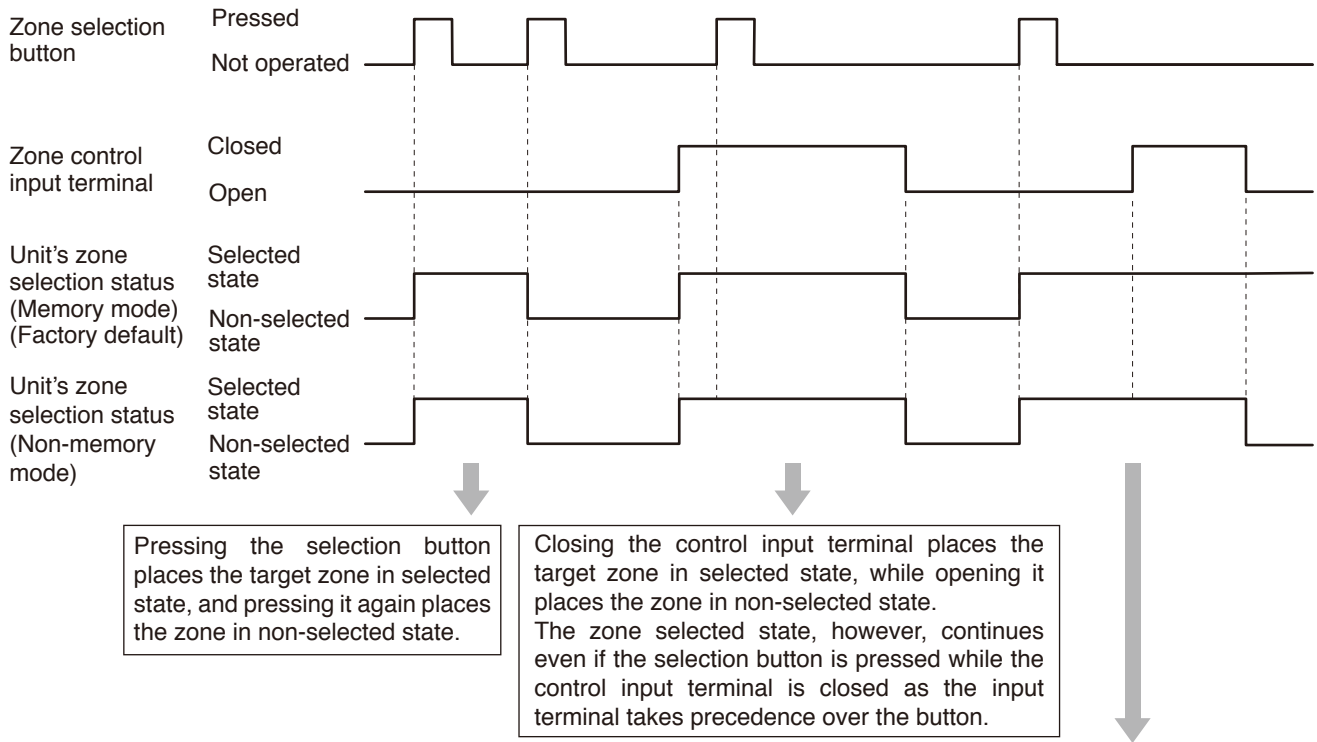

Tip

The selection statuses of the Zones 1 and 2 can be controlled individually.

When the zone control input terminal is opened after being closed while the zone is placed in selected state by pressing the Zone selection button

Memory mode: Memorizes the zone selection button operation and maintains the zone in selected state.

Non-memory mode: Does not memorize the zone selection button operation and places the zone in non-selected state.

17. SETTINGS ON THE BROWSER

You can perform the settings and the displays shown below via the network by connecting a PC to the A-3600D Series mixer amplifier from the browser*1.

- Status display*2
- EQ parameter control and display
- Setting content display
- Input priority setting and display
- Network setting
- Account setting
- Firmware update
- Log output
- Importing and exporting the configuration file

*1 The browsers that have been verified to work are Microsoft Edge, Google Chrome, and Mozilla Firefox.

Notes

- Microsoft Edge is the registered trademark of Microsoft Corporation in the United States and other countries.
- Google Chrome is the trademark of Google LLC in the United States and other countries.
- Mozilla and Firefox are the trademarks of The Mozilla Foundation in the United States and other countries.

*2 If the volume value is set to the minimum on this screen, no sound is output even if you set the unit's front-mounted volume control knobs to the maximum position. Also, the volume value set on this screen becomes the maximum setting value, disabling the unit's front-mounted volume control knobs to increase the volume value exceeding this value.

For the details of the browser settings, refer to the separate setup manual, which can be downloaded from the TOA DATA Library (<https://www.toa-products.com/international/>).

18. BLOCK DIAGRAM

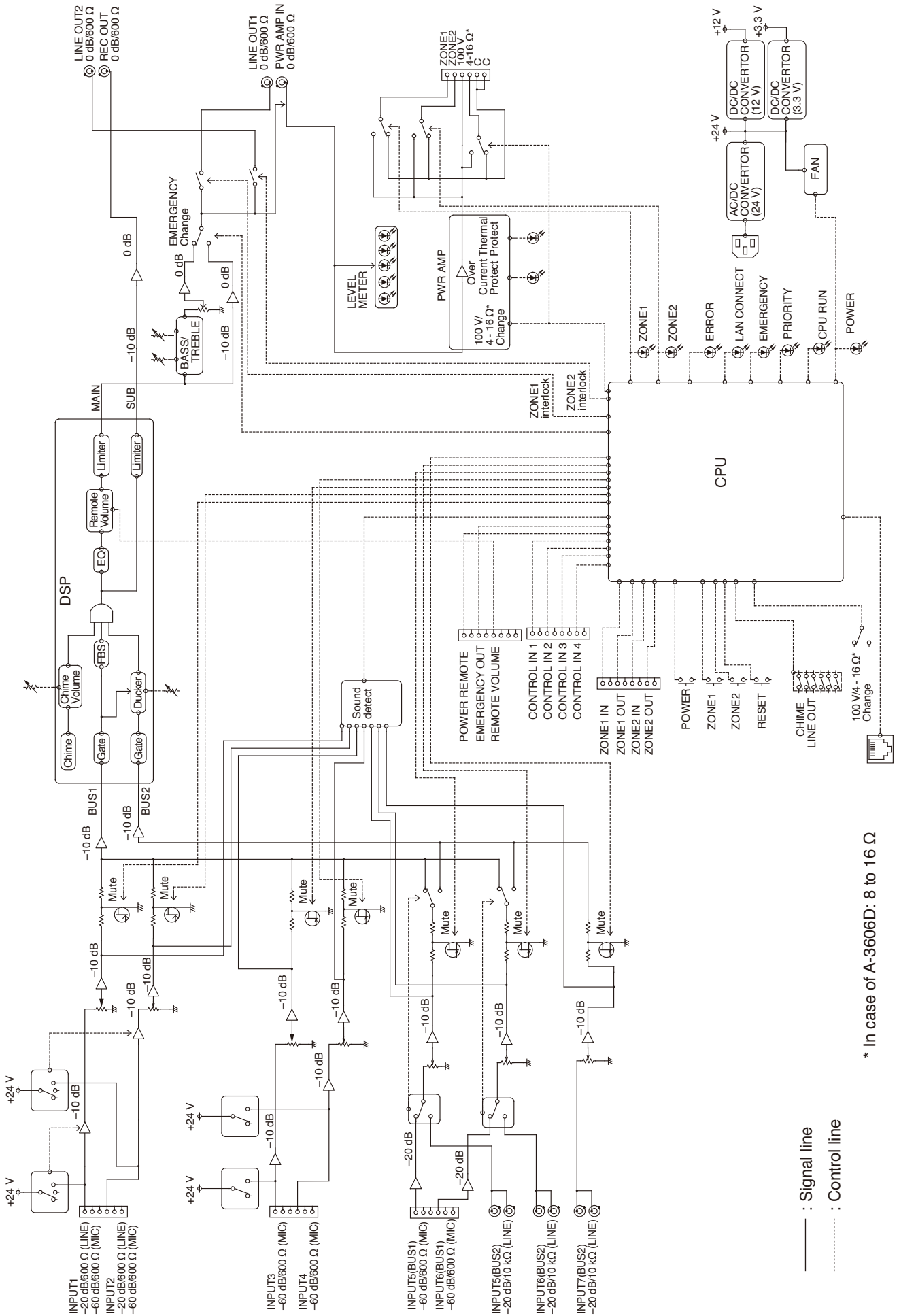

— : Signal line
 - - - : Control line

* In case of A-3606D: 8 to 16 Ω

19. SPECIFICATIONS

	A-3606D	A-3612D	A-3624D	A-3648D
Power Source	100 to 240 V AC, 50/60 Hz			
Rated Output	60 W	120 W	240 W	480 W
Power/Current Consumption	96 W (rated output), 40 W (based on EN62368)	171 W (rated output), 48 W (based on EN62368)	314 W (rated output), 70 W (based on EN62368)	601 W (rated output), 113 W (based on EN62368)
	200 mA or less (when power switch is OFF)			
Frequency Response	50 Hz to 20 kHz \pm 3 dB (1/8 rated output)			
Distortion	1% or less at 1 kHz, rated power (20 kHz LPF (AUX-0025))			
Tone Control	Bass: \pm 10 dB at 100 Hz Treble: \pm 10 dB at 10 kHz			
Signal to Noise Ratio	88 dB or more (Master volume: min) 76 dB or more (Master volume: max) 55 dB or more (INPUT 1 to 6) 72 dB or more (INPUT 7) (A-weighted)			
Audio Input				
INPUT 1, 2	-60 dB* (MIC)/-20 dB* (LINE) selectable, 600 Ω , electronically-balanced, removable terminal block (3.81 mm, 3 pins) Note MIC inputs are equipped with phantom power (24 V DC, ON/OFF switchable).			
INPUT 3, 4	-60 dB*, 600 Ω , electronically-balanced, removable terminal block (3.81 mm, 3 pins) Note Equipped with phantom power (24 V DC, ON/OFF switchable).			
INPUT 5, 6	MIC (BUS 1)/LINE (BUS 2) selectable MIC: -60 dB*, 600 Ω , electronically-balanced, removable terminal block (3.81 mm, 3 pins) LINE: -20 dB*, 10 k Ω , unbalanced, RCA pin jack x 2			
INPUT 7	-20 dB*, 10 k Ω , unbalanced, RCA pin jack x 2			
PWR AMP IN	0 dB*, 600 Ω , unbalanced, RCA pin jack			
Input Bus	INPUT 1 to 4: BUS 1 INPUT 5, 6: BUS 1/BUS 2 selectable INPUT 7: BUS 2			
Audio Output				
SPEAKER OUT	Low impedance (8 to 16 Ω)/ High impedance (DIRECT, ZONE 1 /ZONE 2: 100 V/ total 170 Ω) (ZONE 1/ZONE 2 is selectable, Max. 60 W per output)	Low impedance (4 to 16 Ω)/ High impedance (DIRECT, ZONE 1 /ZONE 2: 100 V/ total 83 Ω) (ZONE 1/ZONE 2 is selectable, Max. 120 W per output)	Low impedance (4 to 16 Ω)/ High impedance (DIRECT, ZONE 1 /ZONE 2: 100 V/ total 42 Ω) (ZONE 1/ZONE 2 is selectable, Max. 240 W per output)	Low impedance (4 to 16 Ω)/ High impedance (DIRECT, ZONE 1 /ZONE 2: 100 V/ total 21 Ω) (ZONE 1/ZONE 2 is selectable, Max. 480 W per output)
	removable terminal block (5.00 mm, 6 pins)			
REC OUT	0 dB*, 600 Ω , unbalanced, RCA pin jack			
LINE OUT 1, 2	0 dB*, 600 Ω , unbalanced, RCA pin jack (Interlock with zone selection is possible.)			
Control Input				
CONTROL IN	4 channels, no-voltage make contact input, open voltage: 35 V DC or less, short-circuit current: 10 mA or less, removable terminal block (3.81 mm, 4 pins)			
REMOTE VOLUME	Removable terminal block (3.50 mm, 4 pins)			
ZONE CONTROL IN	No-voltage make contact input, open voltage: 35 V DC or less, short-circuit current: 10 mA or less, removable terminal block (3.81 mm, 4 pins)			

	A-3606D	A-3612D	A-3624D	A-3648D
Control Output				
POWER REMOTE OUT	Open collector output, withstand voltage: 30 V DC or less, control current: 25 mA or less, removable terminal block (3.50 mm, 4 pins)			
EMERGENCY OUT	Open collector output, withstand voltage: 30 V DC or less, control current: 25 mA or less, removable terminal block (3.50 mm, 4 pins)			
ZONE CONTROL OUT	Open collector output, withstand voltage: 30 V DC or less, control current: 25 mA or less, removable terminal block (3.81 mm, 4 pins)			
Chime	1-note, 2-note, or ascending 4-note chime or None selectable with switch setting			
Indicators	LED level meter, Power indicator, Network connection confirmation indicator, Priority broadcast indicator, Emergency broadcast indicator, Thermal protection indicator, Overcurrent protection indicator, CPU running indicator, Error indicator, Zone indicator (1,2)			
Operating Temperature	-10 to +40 °C (14 to 104 °F)			
Operating Humidity	85%RH or less (no condensation)			
Finish	Panel: ABS resin, black Case: Surface-treated steel plate, black, paint			
Dimensions	420 (w) x 96.1 (h) x 313.1 (d) mm or 16.54" x 3.78" x 12.33"			
Weight	5 kg (11.02 lb)			5.2 kg (11.46 lb)

* 0 dB = 1 V

Note: The design and specifications are subject to change without notice for improvement.

• **Accessories**

Power cord (2 m (6.56 ft))	1
Audio input removable terminal plug (3.81 mm, 3 pins)	6
Control I/O removable terminal plug (3.81 mm, 4 pins)	4
Remote control removable terminal plug (3.50 mm, 4 pins)	2
Speaker out removable terminal plug (5.00 mm, 6 pins)	1
Volume control cover	4

• **Optional products**

Rack mounting bracket : MB-25B
Perforated panel: PF-013B